



AW30-EVI-M
AW45-EVI-M
AW90-EVI-M
AWC30/90-EVI-M



DC Inverter Air to Water Heat Pump

User's manual

Before operating this product, please read the instructions carefully and keep this manual for future use.

Catalogue

1. Product Specifications	3
1-1 Specifications	3
1-2 External Dimensions	5
2. Product Data	9
2-1 Electrical Wiring Diagrams	9
2-2 Capacity tables	13
2-2.1 Correction by temperature	13
2-2.2 Operation temperature range	16
3. Installation	17
3-1 Selecting the Installation Site	17
3-1.1 Installation Conditions	17
3-1.2 Installation space requirements	18
3-2 Unit Installation	18
4. System Design	19
4-1 Water Pipe Installation	19
4-1.1 Caution for water pipe installation	19
4-1.2 Installing the water pipes	21
4-2 Ensuring enough water in the water circuit	21
4-2.1 Required amount of water	21
4-3 Inlet/Outlet pipe connection size and material	21
5. Installation	22
5-1 Wiring	22
6. Wiring Design	30
6-1 Connect to power supply	30
7. Touchscreen Panel Overview	32
8.Failure code list	69

1. Product Specifications

1-1. Specifications

Model information					
Model			AW30-EVI-M	AW45-EVI-M	AW90-EVI-M
Performance					
Min/max heating capacity (1)		kW	15.2~28.7	13.7~43.7	27.4~89.6
El. heating power input min/max (1)		W	3467~7488	3325~12077	6650~24254
C.O.P min/max (1)		W/W	3.83~4.43	3.62~4.42	3.68~4.50
Min/max heating capacity (2)		kW	12.2~29.4	13.6~43.2	28.2~89.5
El. heating power input min/max (2)		W	3769~9035	4156~14308	8212~28300
C.O.P min/max (2)		W/W	3.26~3.43	2.99~3.38	3.16~3.48
Min/max cooling capacity (3)		kW	15.2~26.8	17.7~32.0	36.4~66.0
El. cooling power input min/max (3)		W	3253~8765	3491~11771	6982~23742
E.E.R. min/max (3)		W/W	3.06~4.68	2.72~5.09	2.8~5.19
Min/max cooling capacity (4) (A35/W7)		kW	7.3~21.2	11.2~29.9	23.4~61.2
El. cooling power input min/max (4)		W	3121~7960	3529~11640	6880~23450
Min/max ambient working temp. in heating mode		°C	-25-45	-25-45	-20-45
Min/max ambient working temp. in cooling mode		°C	20-45	20-45	20-45
Max flow temp. in heating mode		°C	60	60	60
Min set temp. in heating mode		°C	20	20	20
Min set temp. in cooling mode		°C	7	7	7
Sound power level	Outdoor unit	dB (A)	62	66	69
	Indoor unit	dB (A)	/	/	/
Electrical heaters					
Heating cable - condense water		W	140	400	400*2
Compressor heater		W	30	60	60*2
Anti - Freeze el. heater		Power supply	V / Hz /	/	/
Anti - Freeze el. heater		Rated power	W	/	/
Power supply					
Power supply - Outdoor unit	Outdoor unit	V / Hz / N	380-415V/3N~/50Hz	380-415V/3N~/50Hz	380-415V/3N~/50Hz
	Fuse Outdoor unit	A	3p/25A/C	3p/40A/C	2x40A/C
Power supply - Indoor unit	Indoor unit	V / Hz / N	230V/50Hz/1N	230V/50Hz/1N	230V/50Hz/1N
	Fuse Indoor unit	A	1p/6A/C	1p/6A/C	1p/6A/C
Components					
Fan	Quantity	pcs	2	1	2
	Airflow	m ³ /h	5250*2	13500	13500*2
	Rated power	W	93*2	700	700*2
	Blade diameter	mm	552*2	760	760*2
Plate heat exchanger	Water press. drop	kPa	60	80	100
	Piping connection	Inch	1 1/2" Inner gorve	2" Inner gorve	Dn65 Flange
Refrigerant	type	/	R410A	R410A	R410A
	charge	kg	5.2kg	8kg	8kg*2
	GWP	/	2088	2088	2088
	t CO ₂ Equiv.	/	10.9	16.7	33.4
Compressor	Manufacturer	/	Panasonic Wanbao	SIAM	SIAM
	type	/	Inverter+EVI	Inverter+EVI	Inverter+EVI
	Compressor oil	type	FVC68S	FVC68D	FVC68D
	Comp. oil volume	L	1.9	2.3	2.3*2
Hydraulics					
Minimum water flow		m ³ /h	2.7m ³ /h	5m ³ /h	10m ³ /h
Nominal water flow		m ³ /h	5.2m ³ /h	8m ³ /h	16m ³ /h
Hydraulic connections		Size	1 1/2" Female	2" Female	Dn65 Flange
Flow switch	Manufacturer		ACOL	Hengsen	Hengsen
Flow switch	type		WFS27020BF40-0.5	SLG-01	SLG-01
Dimensions and weight					
Dimensions net (L x D x H)	Outdoor unit	mm	1295*455*1450	1010*1158*1645	2218*1188*1645
	Indoor unit	mm	389*476*135	389*476*165	389*476*165
Dimensions Brutto (L x D x H)	Outdoor unit	mm	1325*475*1580	1120*1260*1820	2310*1310*1820
	Indoor unit	mm	400*490*180	400*490*180	400*490*180
Net weight	Outdoor unit	kg	191	338	704
	Indoor unit	kg	9	9	9
Brutto weight	Outdoor unit	kg	215	401	814
	Indoor unit	kg	10	10	10

1. Product Specifications

- (1) Heating condition: water inlet/outlet temperature: 30 °C/35°C, Ambient temperature: DB 7 °C /WB 6 °C ;
- (2) Heating condition: water inlet/outlet temperature: 40°C/45°C, Ambient temperature: DB 7 °C /WB 6 °C ;
- (3) Cooling condition: water inlet/outlet temperature: 23 °C/18°C, Ambient temperature: DB 35 °C /WB 24 °C ;
- (4) Cooling condition: water inlet/outlet temperature: 12°C/7°C, Ambient temperature: DB 35 °C /WB 24 °C.

1. Product Specifications

1-2. External Dimensions

Unit:mm

AW30-EVI-M

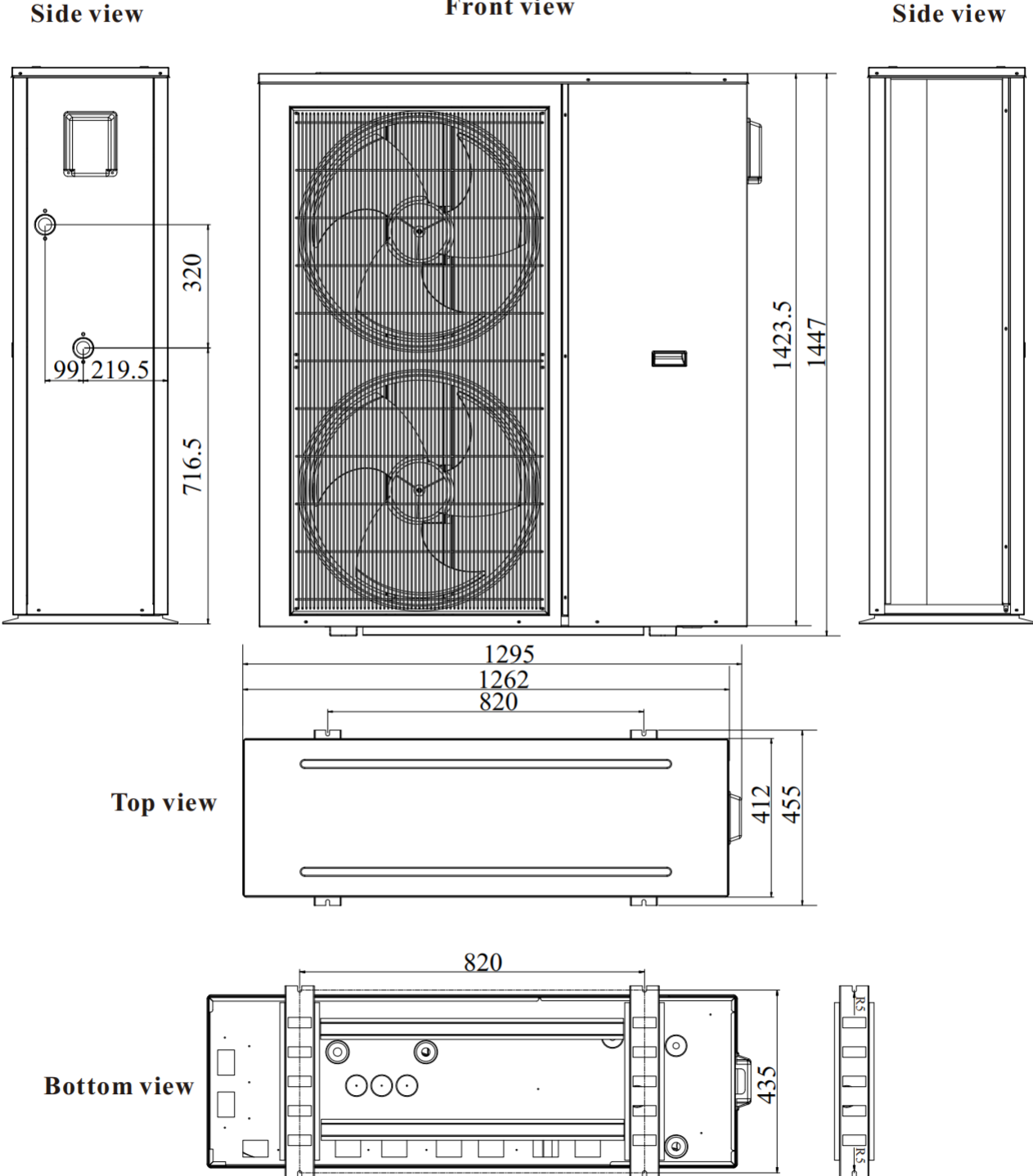

1. Product Specifications

AW45-EVI-M

Unit:mm

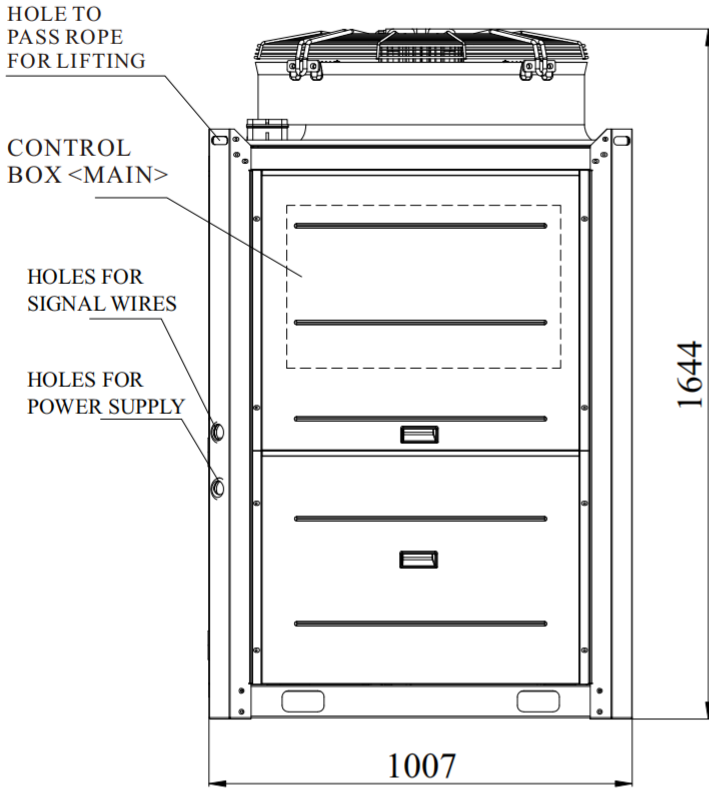

Front view

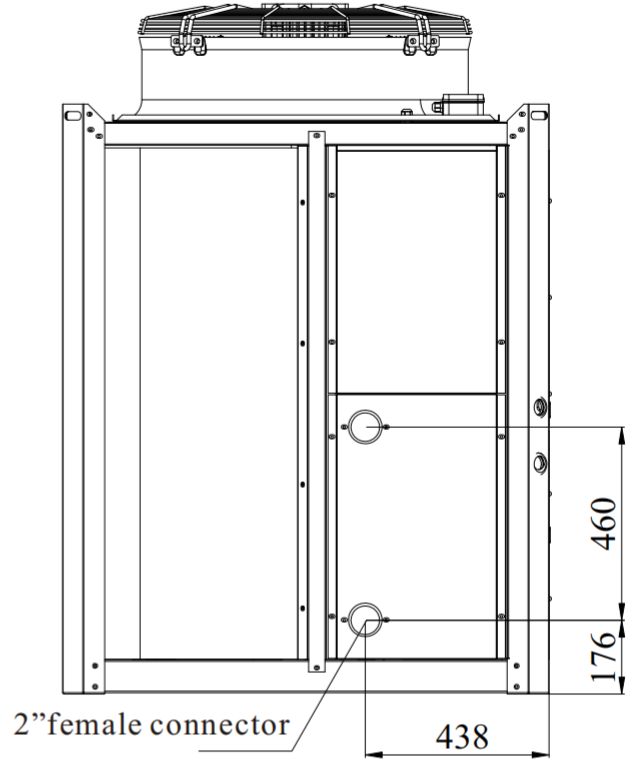

Side view

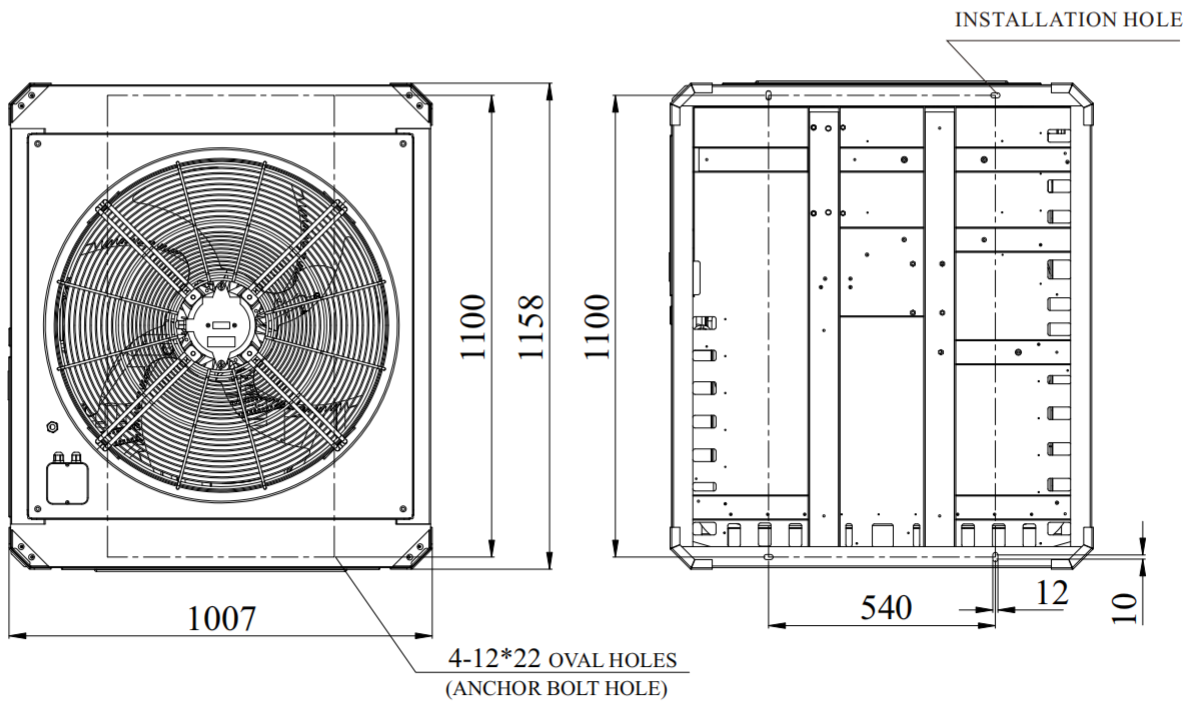

Top view

Bottom view

1. Product Specifications

AW90-EVI-M

CONTROL
BOX <MAIN>

Unit:mm

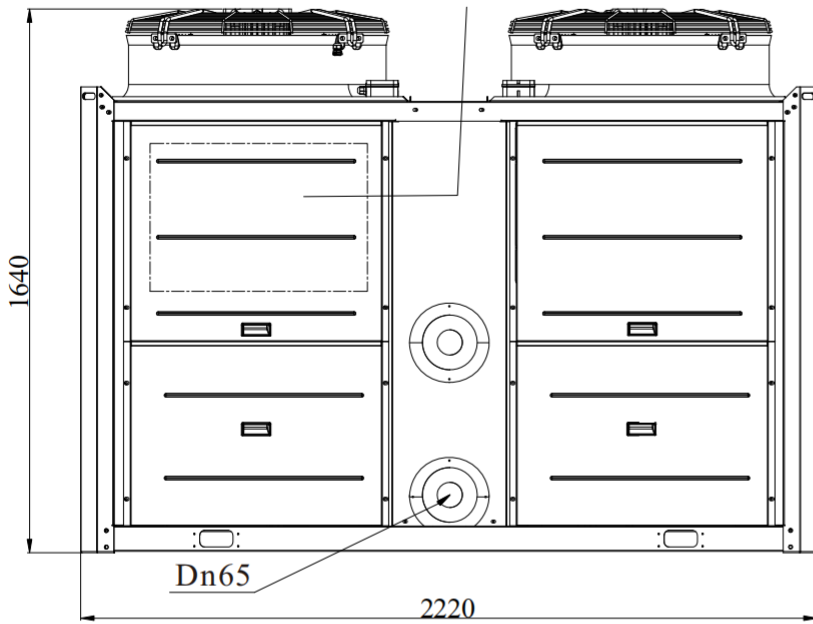

Front view

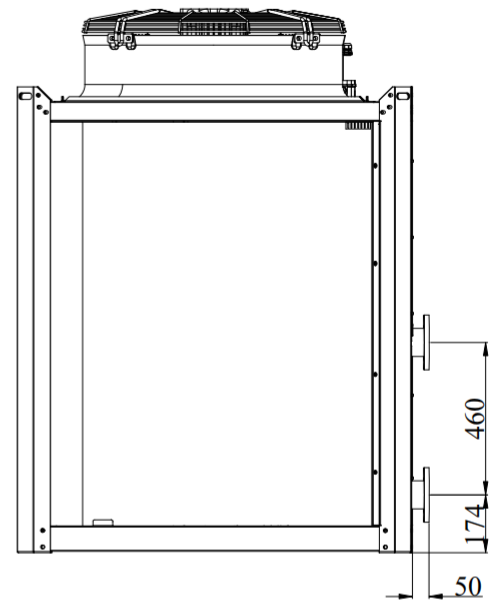

Side view

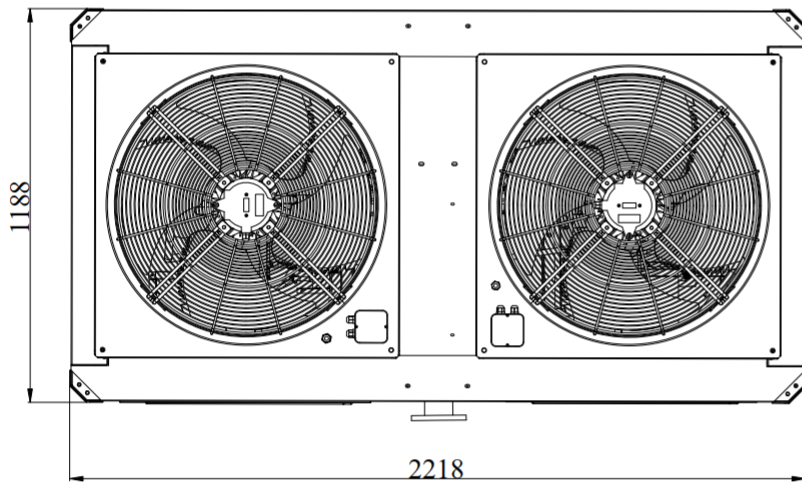

Top view

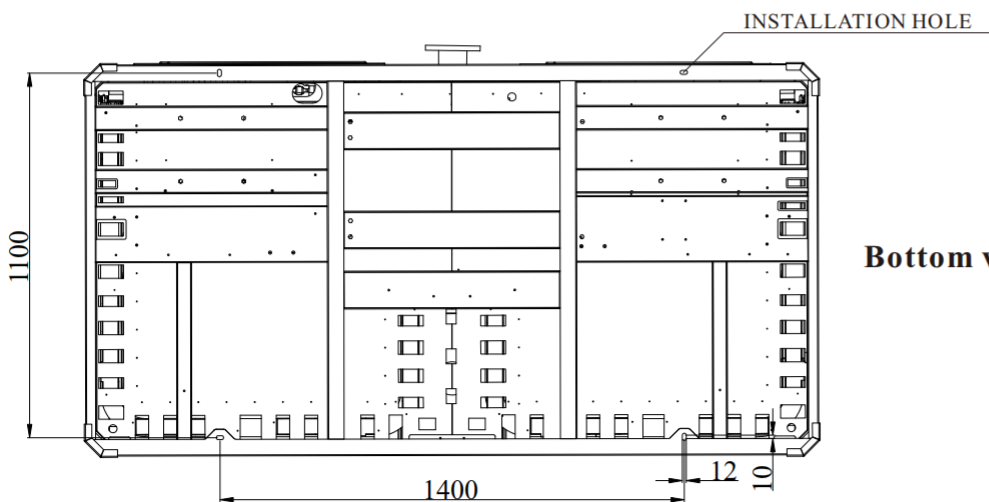

Bottom view

1. Product Specifications

AWC30/90-EVI-M

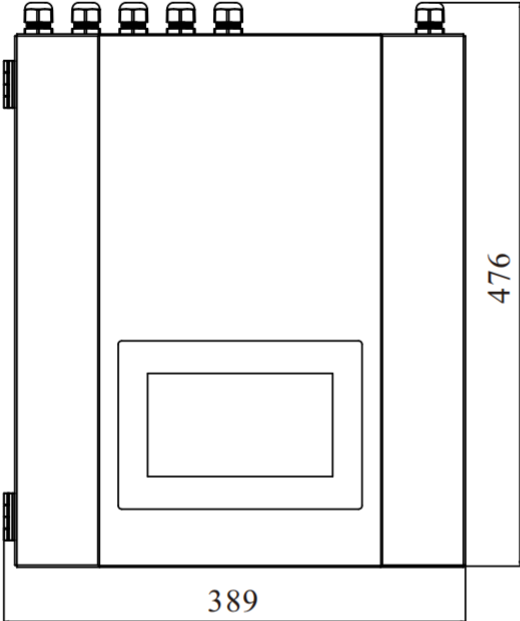

Front view

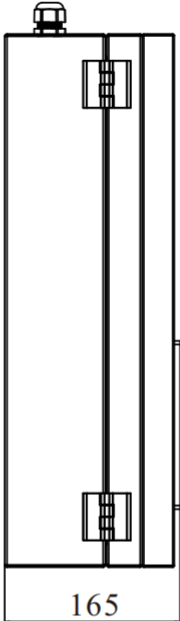

Side view

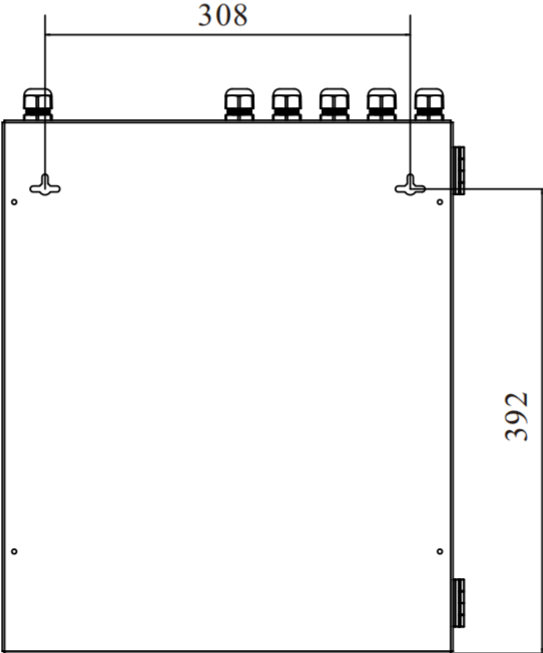

Back view

2. Product Data

2-1. Electrical Wiring Diagrams

AW45-EVI-M--Outdoor unit

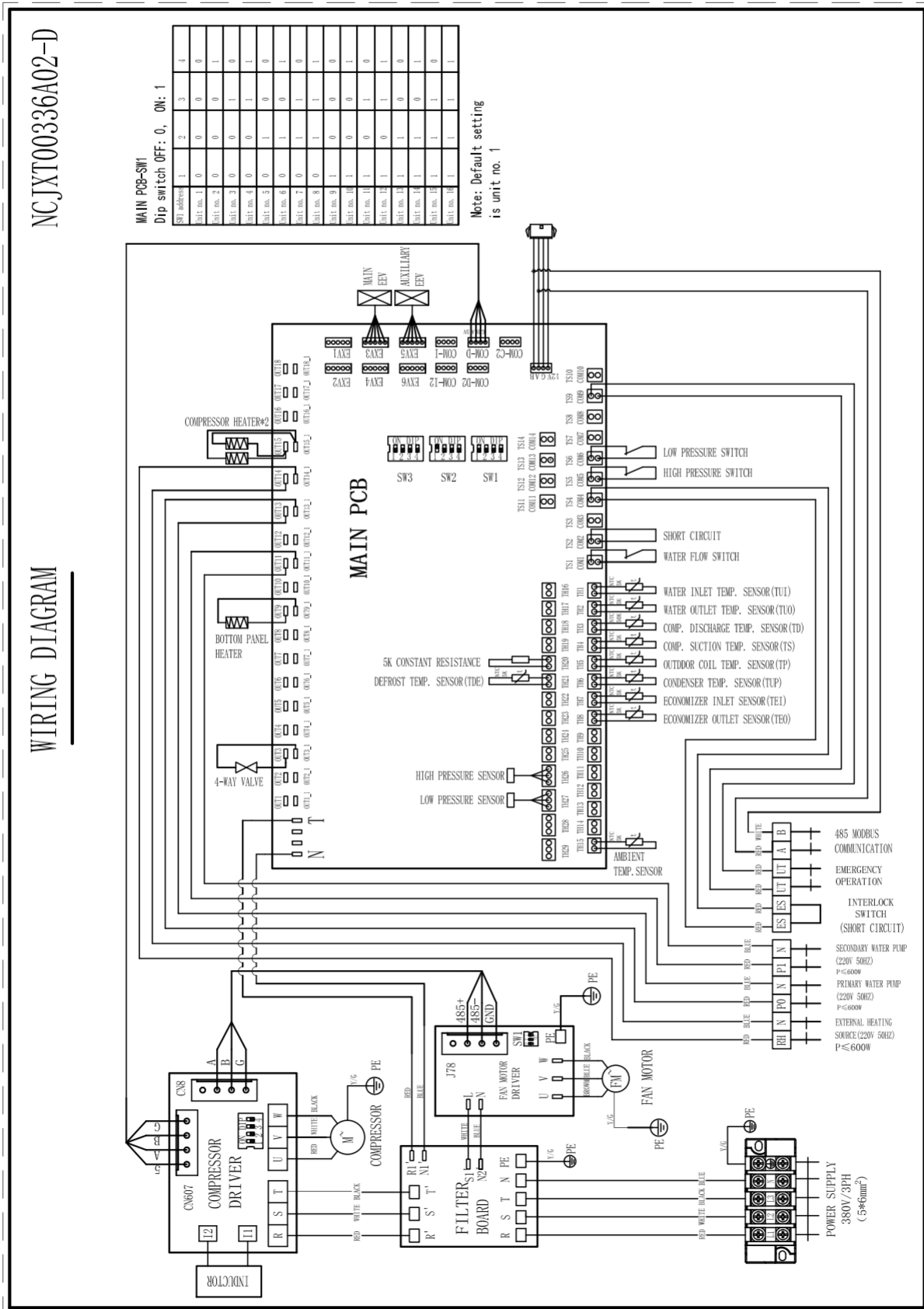

TAKE CARE!
The specifications are subject to change without prior notice.
For actual specifications of the unit, please refer to the specification stickers on the unit.

2. Product Data

2-1. Electrical Wiring Diagrams AW90-EVI-M--Outdoor unit

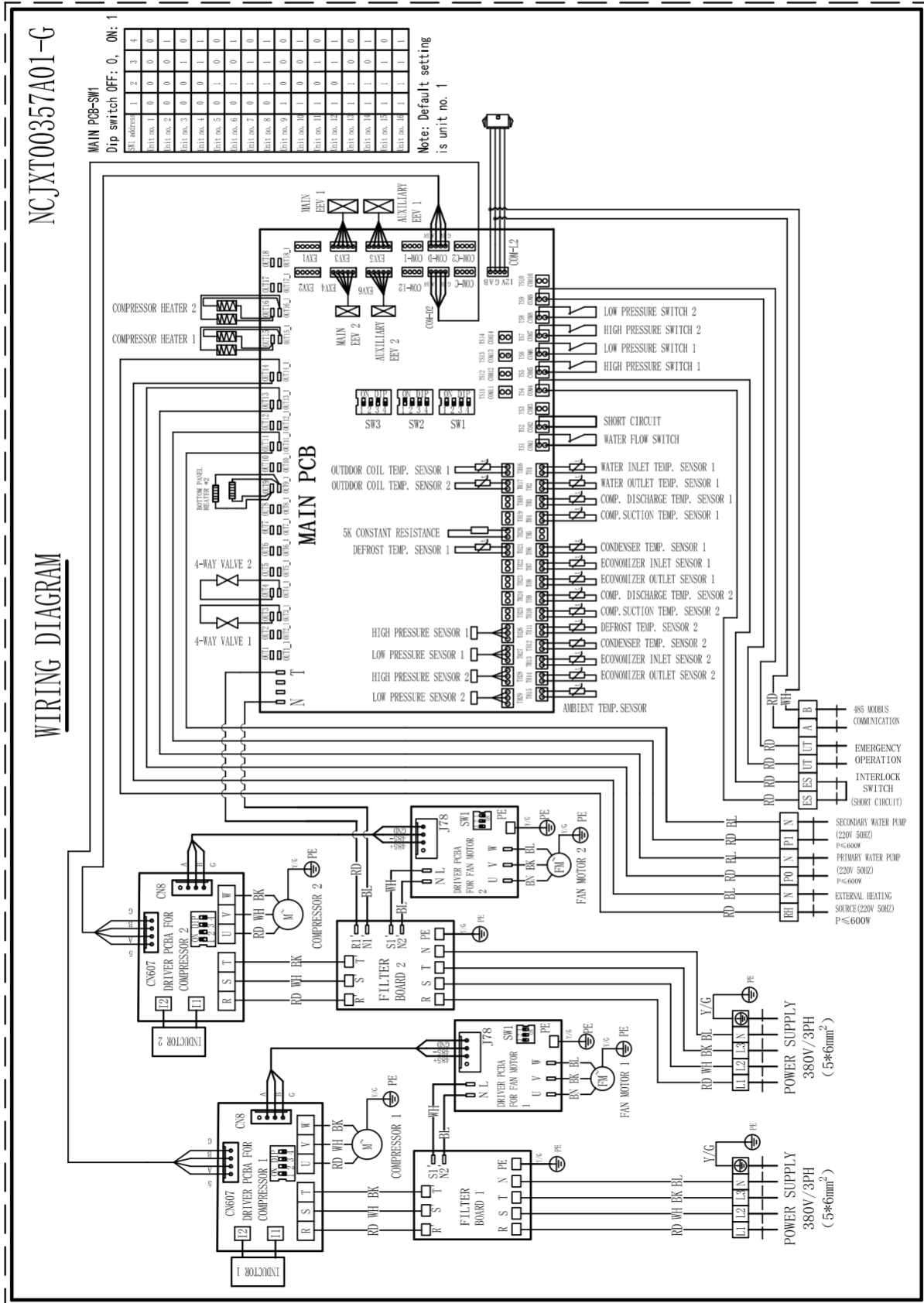

TAKE CARE!
The specifications are subject to change without prior notice.
For actual specifications of the unit, please refer to the specification stickers on the unit.

2. Product Data

2-2. Capacity tables

2-2-1. Heating capacity curve in various conditions

AW30-EVI-M

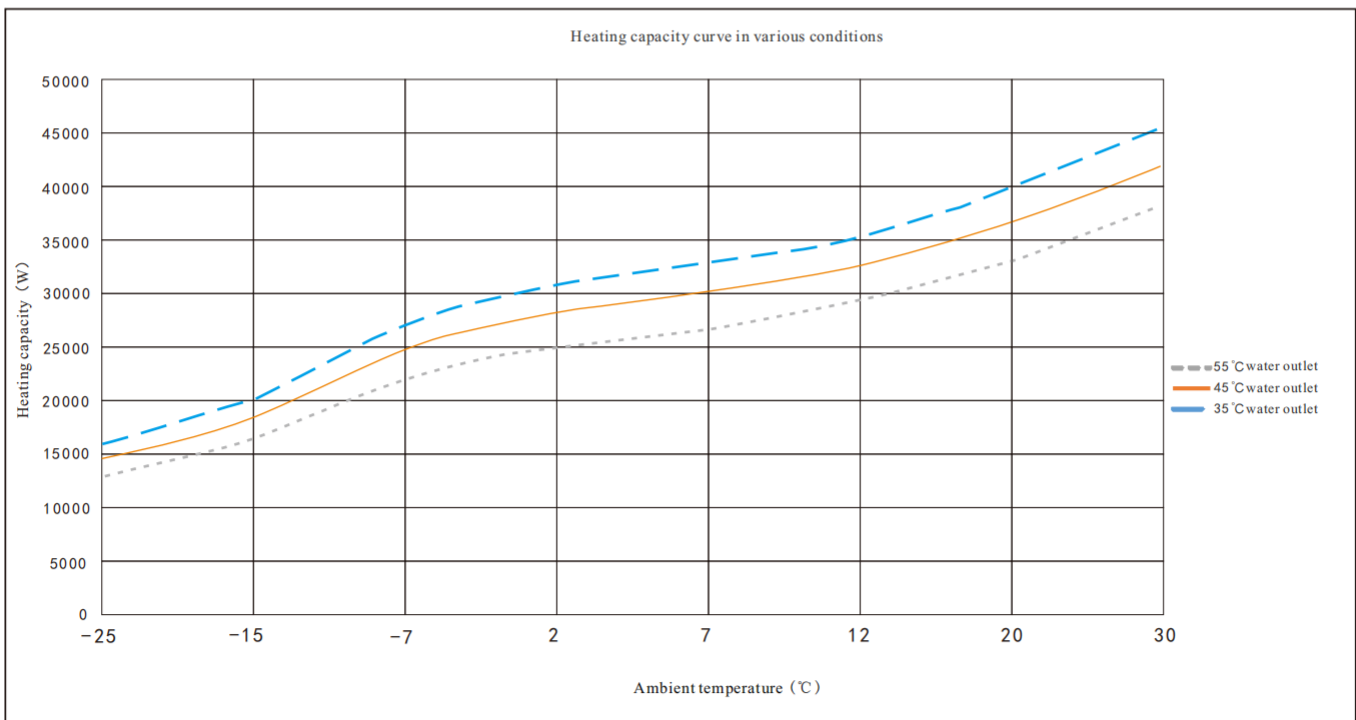
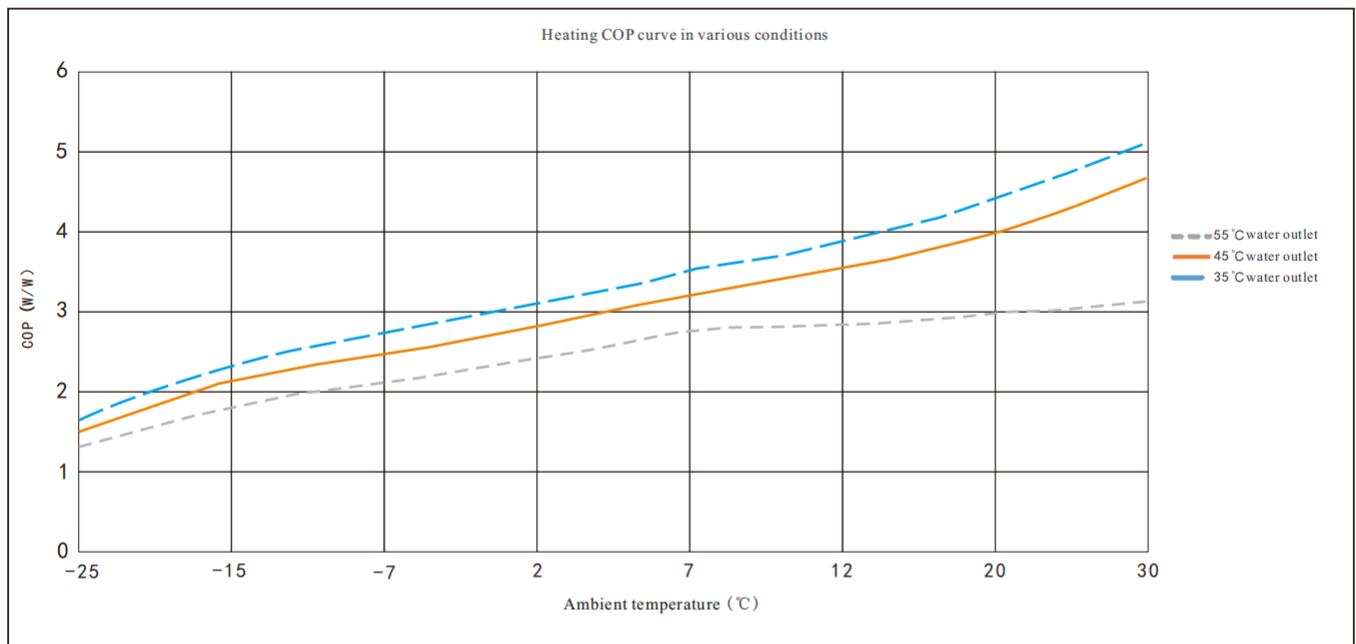

2. Product Data

2-2. Capacity tables

AW45-EVI-M

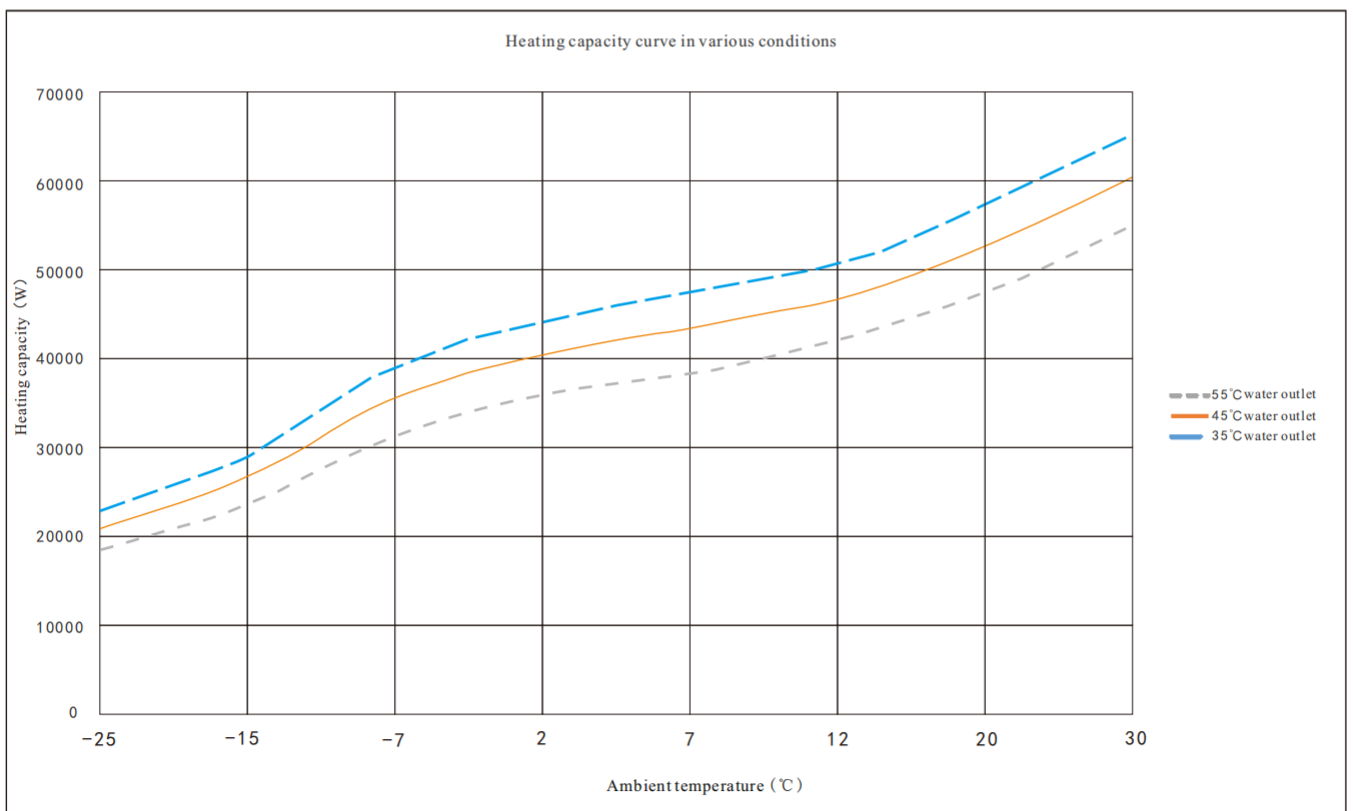
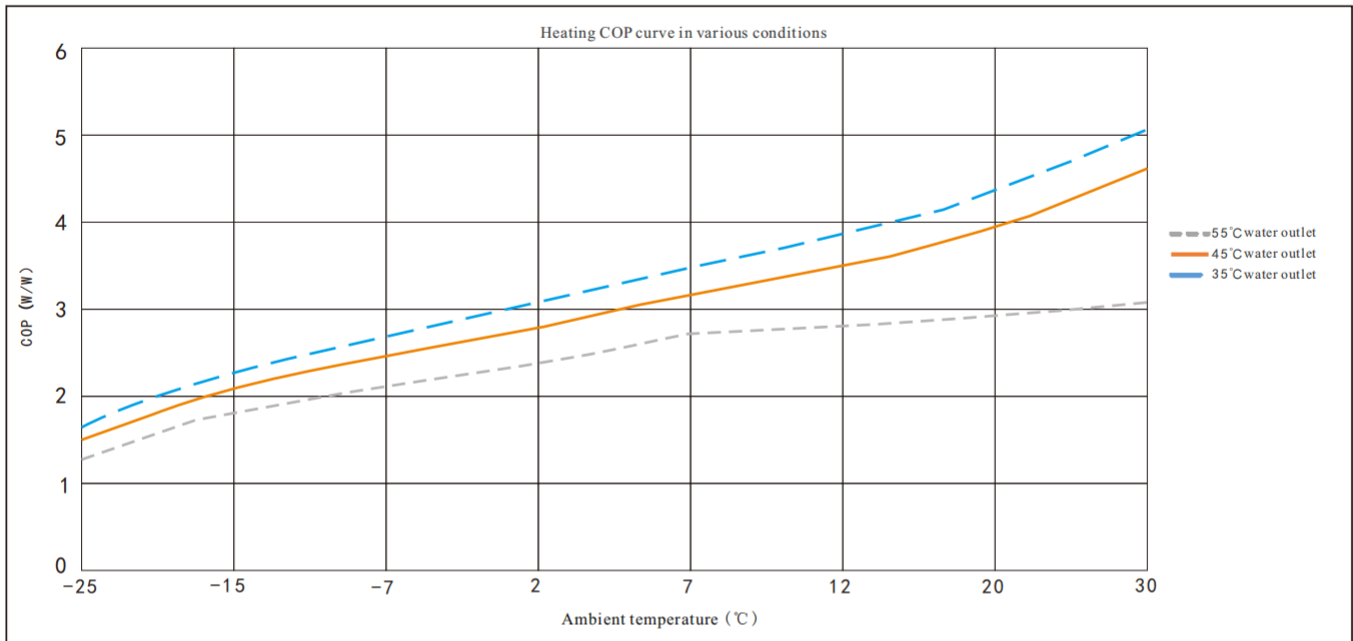

2. Product Data

2-2. Capacity tables

AW90-EVI-M

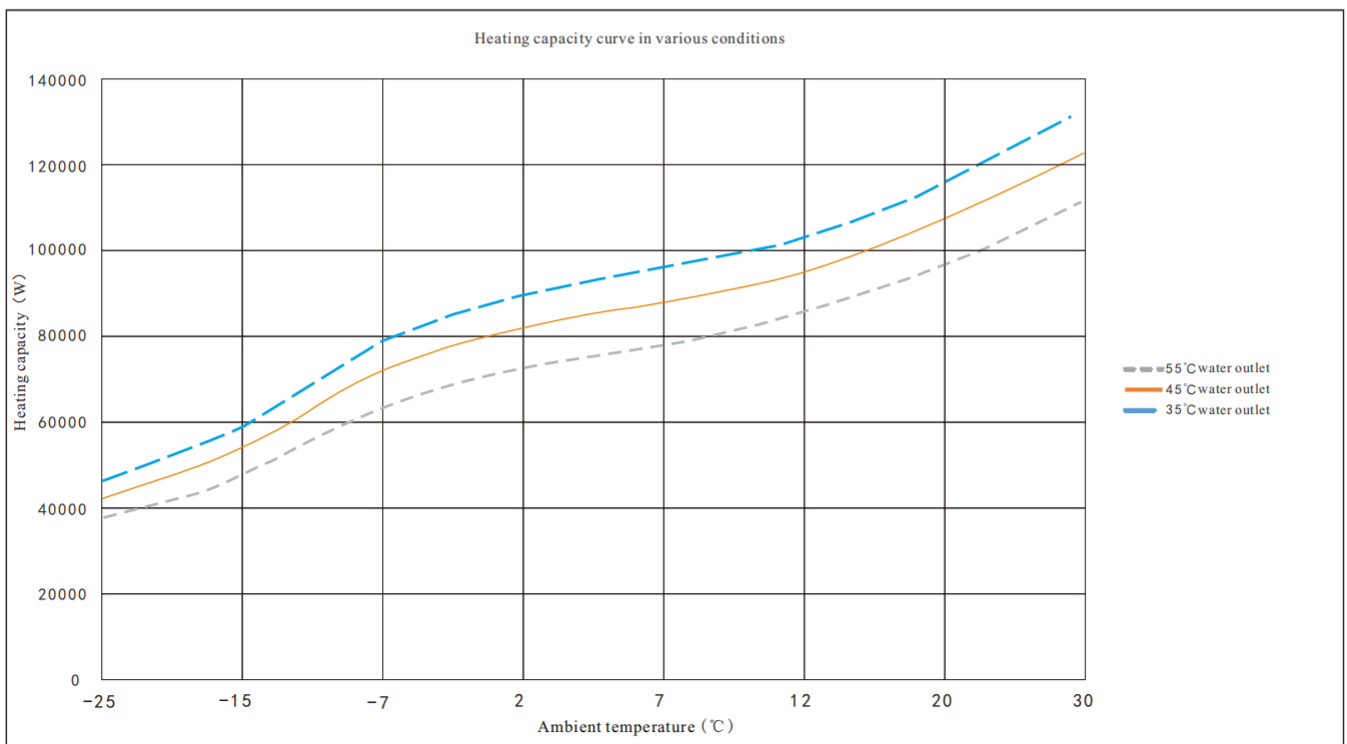
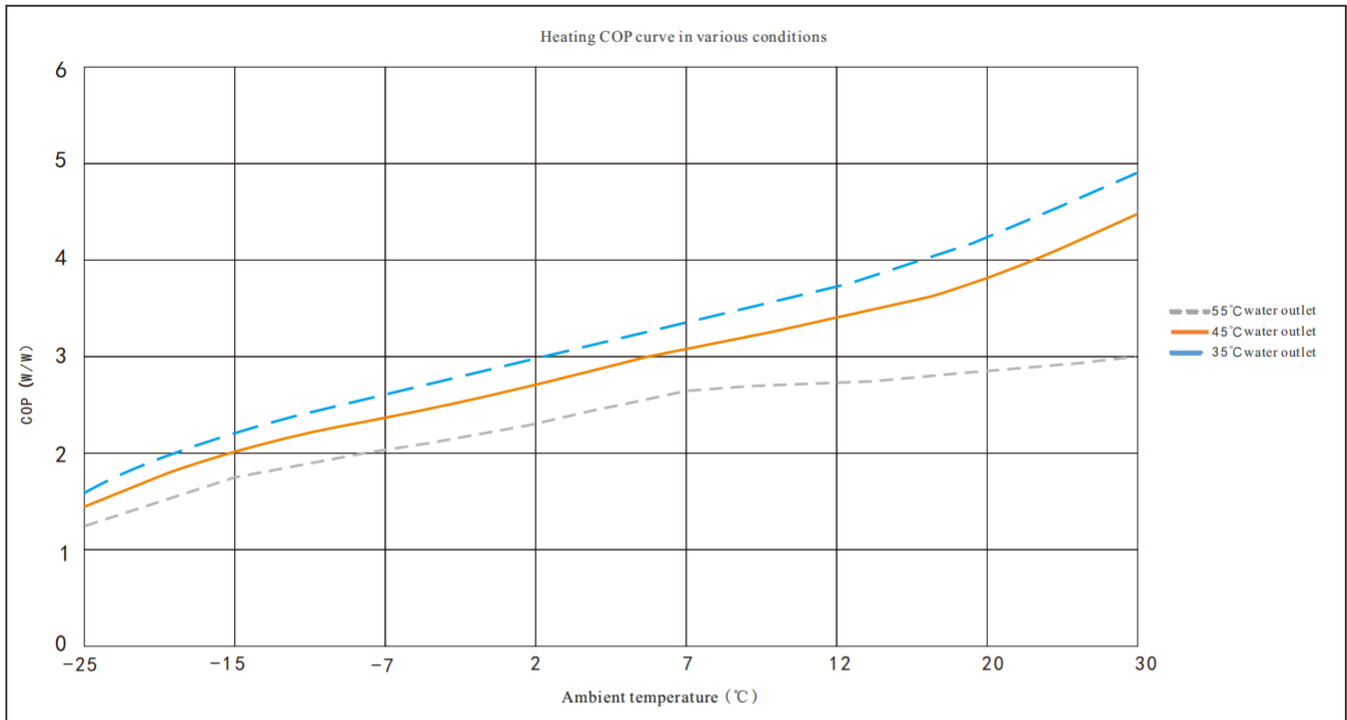

2. Product Data

2-2-2. Operation temperature range

AW30-EVI-M, AW45-EVI-M, AW90-EVI-M

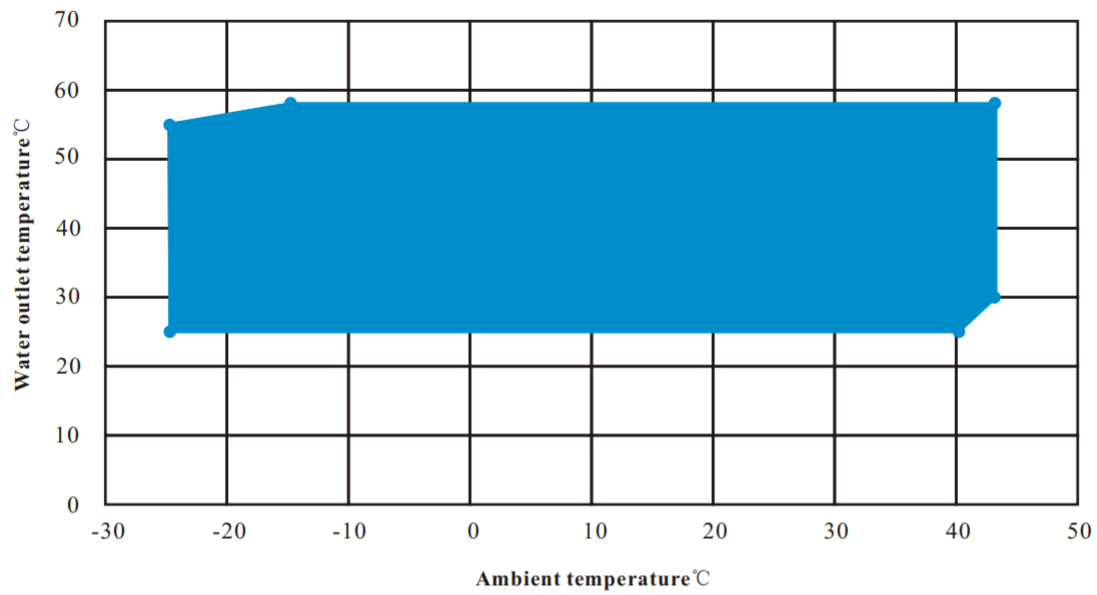

3. Installation

3.1. Selecting the Installation Site

3.1.1 Installation Conditions

Select a installation site that meets the following conditions:

- Unit can have free air circulation.
- The noise from the unit will not be a problem.
- Condense water from the unit can be drained.
- Unit has open space as shown in the drawing 3.1.2.
- Stand of the unit must be at least 50cm high in cold areas, to avoid snow accumulation.

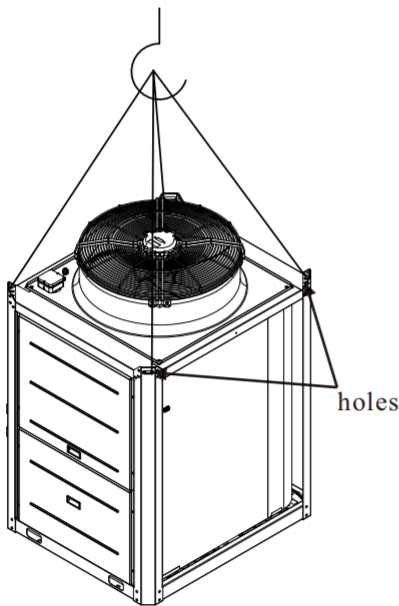
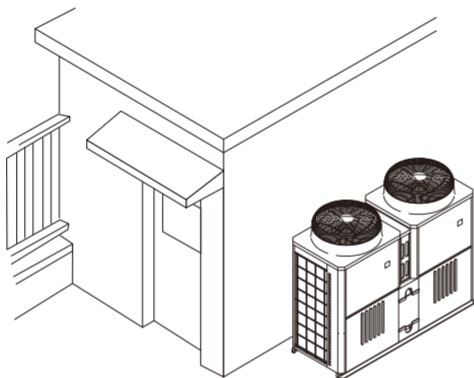

Pass two ropes through four holes of the heat pump and lift it with hook.

Lift of the unit : Rope used for lifting the unit should bear at least 3 times the weight of the unit. Hook should be fixed to the unit, and lifting angle must over 60°

Note : Don't stay under the unit when unit is being lifting up. Add soft material between rope and unit to avoid unit damage.

1. Fix the outdoor unit on the bracket.
2. Four M8 bolts pass through four holes of bracket and of the bottom plate installation holes.
3. Tighten nuts with a wrench.

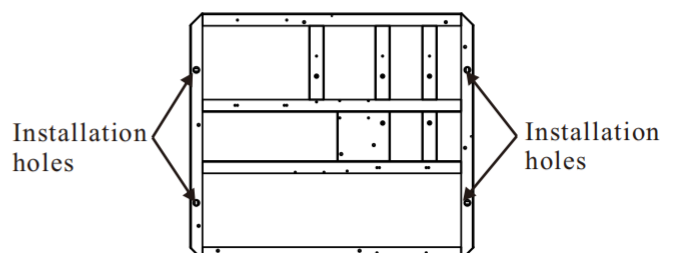

3. Installation

3.1.2. Installation space requirements

1. Single unit installation

Secure enough space around the unit as shown in the figures below.

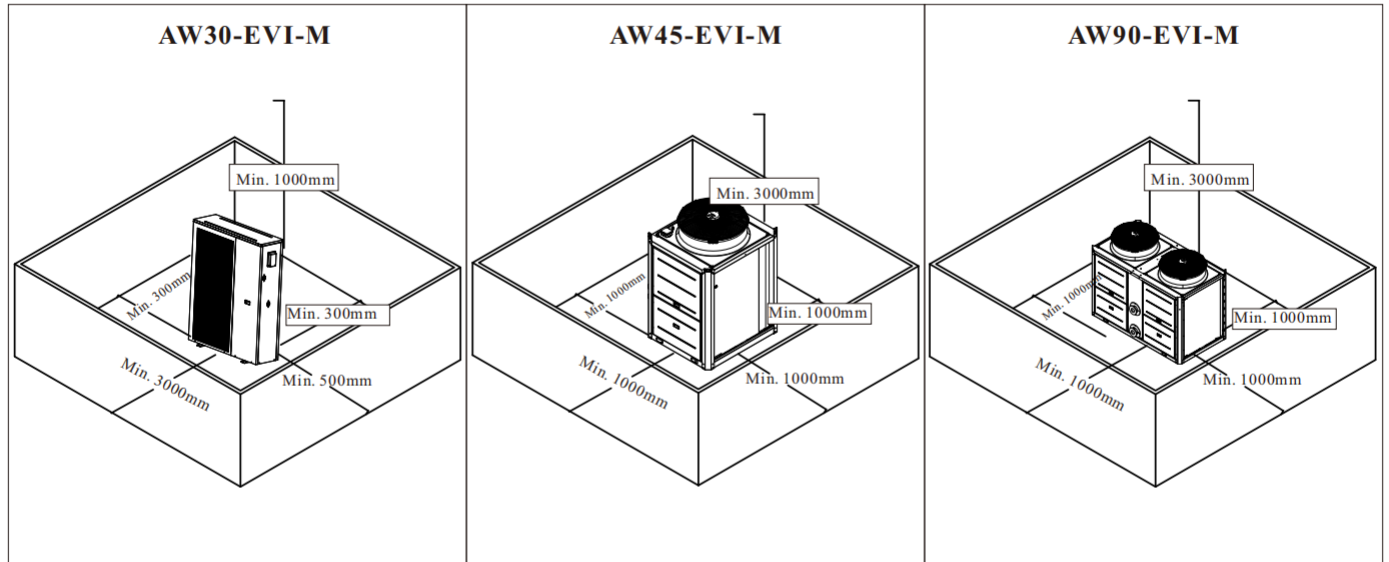

Side-by-side installation

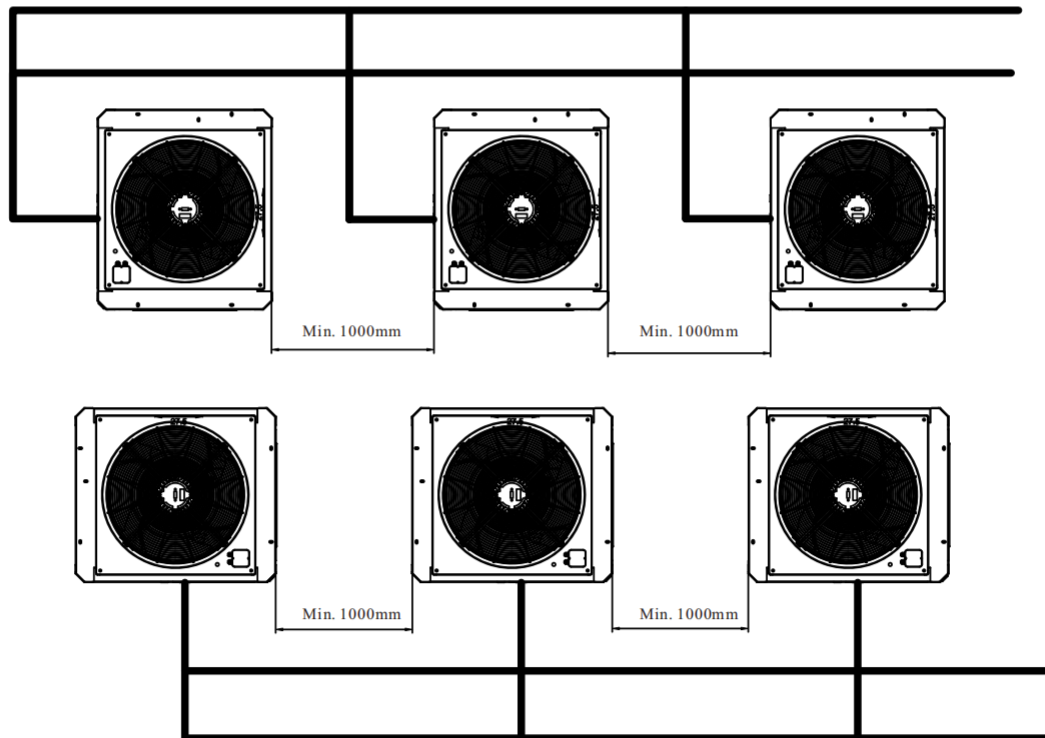

3.2. Unit Installation

The unit must be installed on flat concrete blocks, or a dedicated mounting bracket.

4. System Design

4.1. Water Pipe Installation

4.1.1. Caution for water pipe installation

The installation should be done by qualified installer. Before installation, please make sure the power supply is cut off.

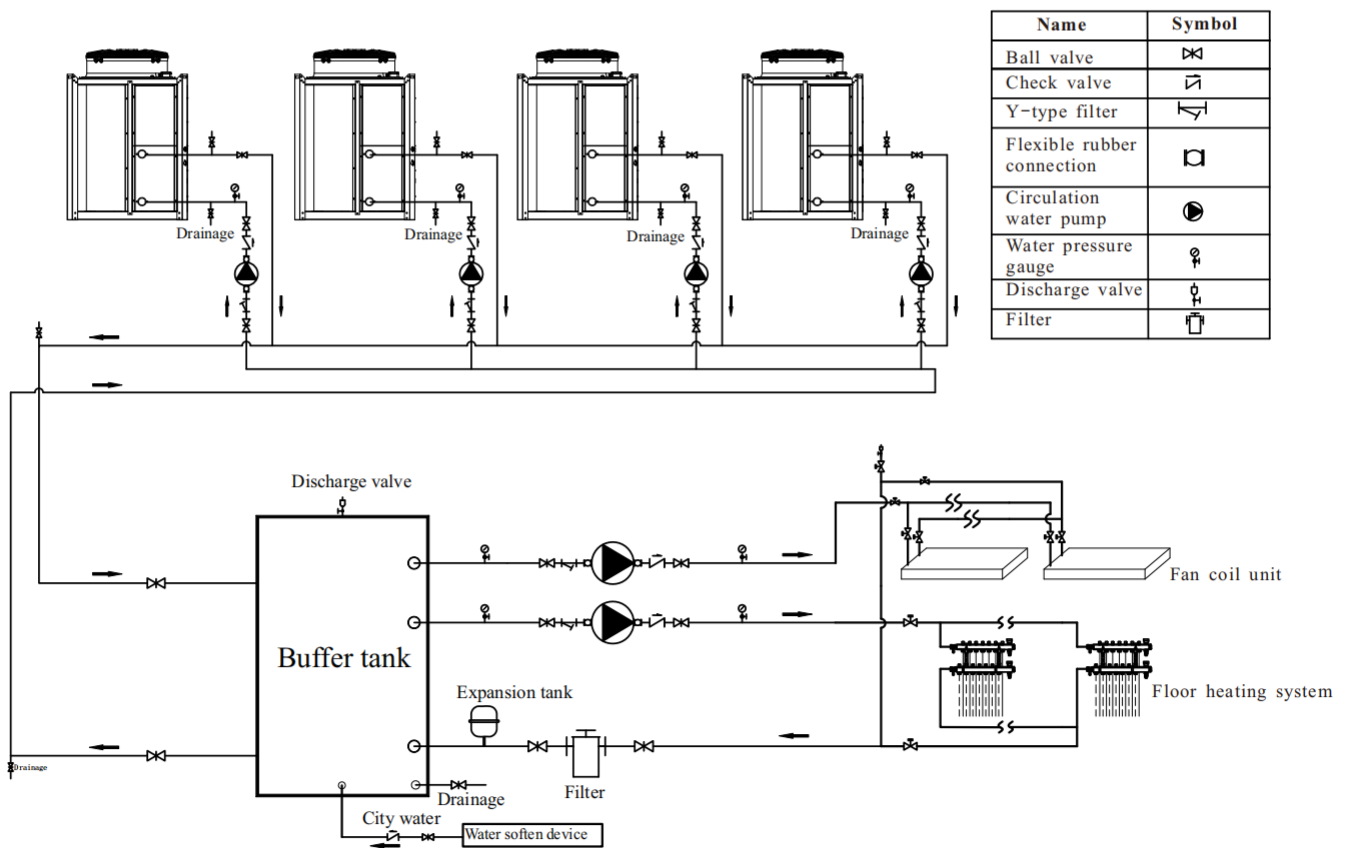
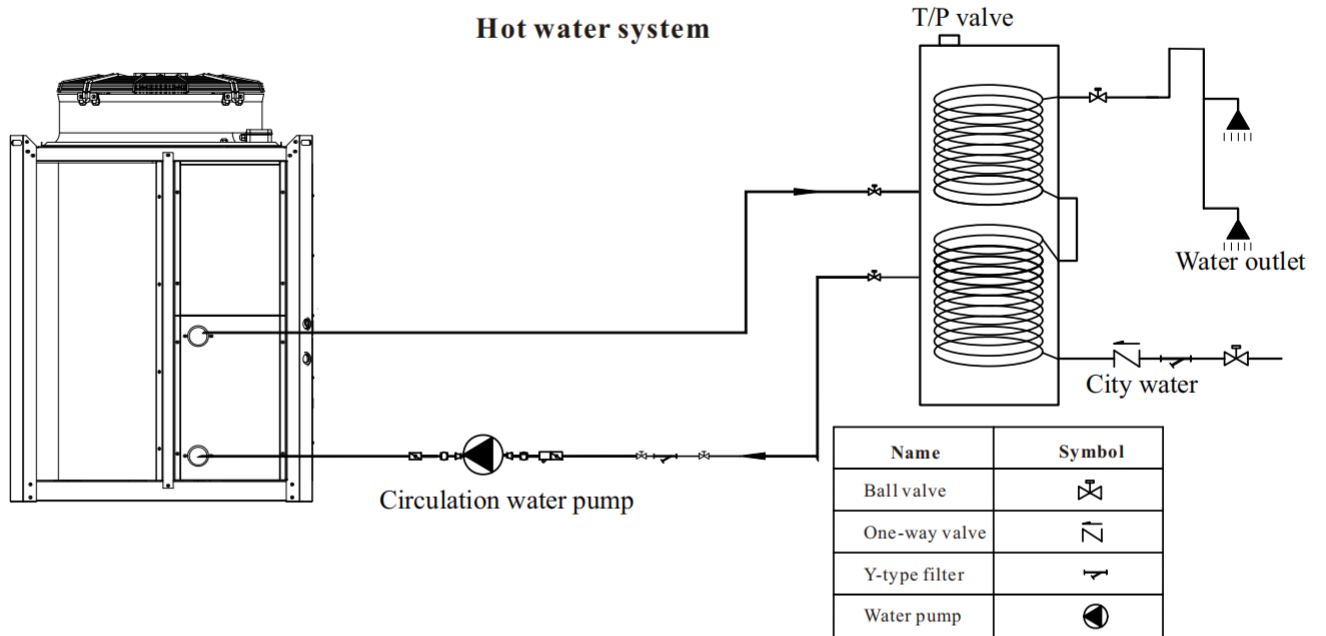

Attention: Maximum 16 units can be connected in parallel.

4. System Design

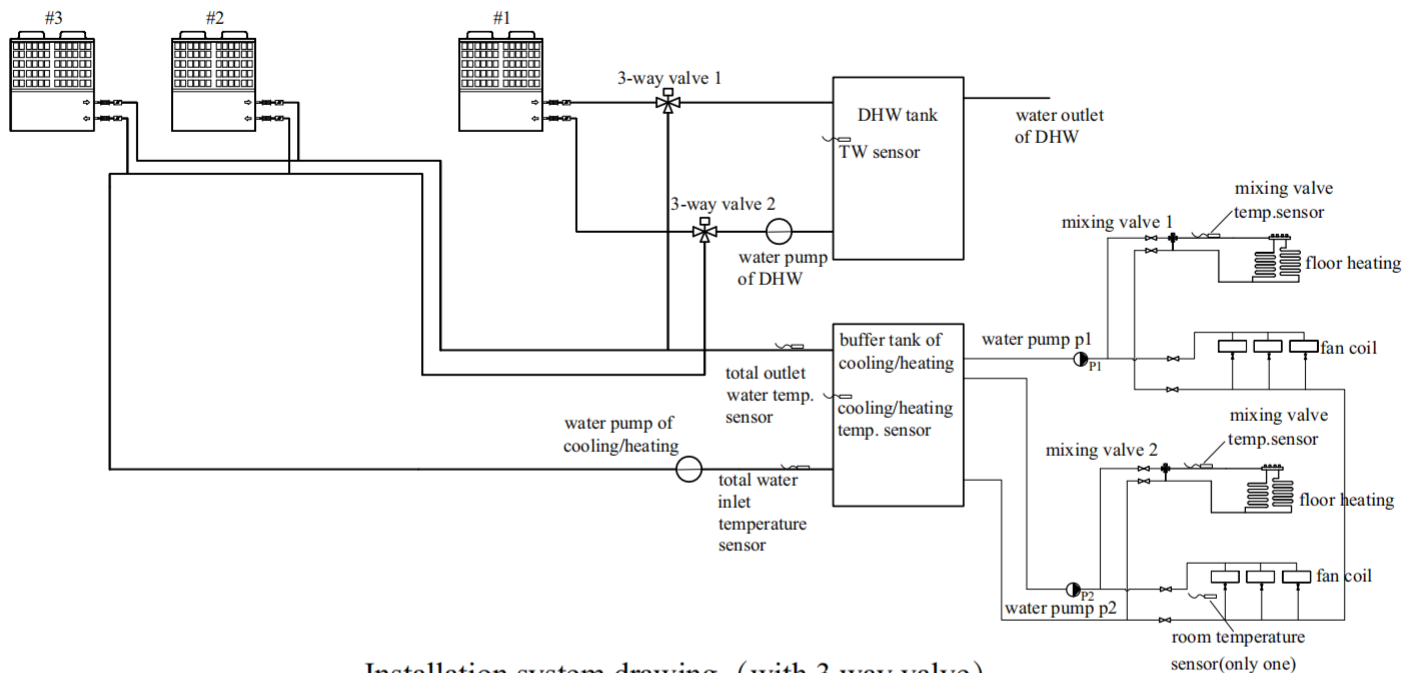

Installation system drawing (with 3 way valve)

4. System Design

4.1.2. Installing the water pipes

Installing the Filter

A mesh filter must be installed in front of the water inlet of the unit and water tank, to keep the water quality and collect impurity contained in the water. Take care to keep the water filter mesh towards the bottom. Ball valve is recommended to be installed at both sides of the filter, so as to clean or change the filter in a easier way.

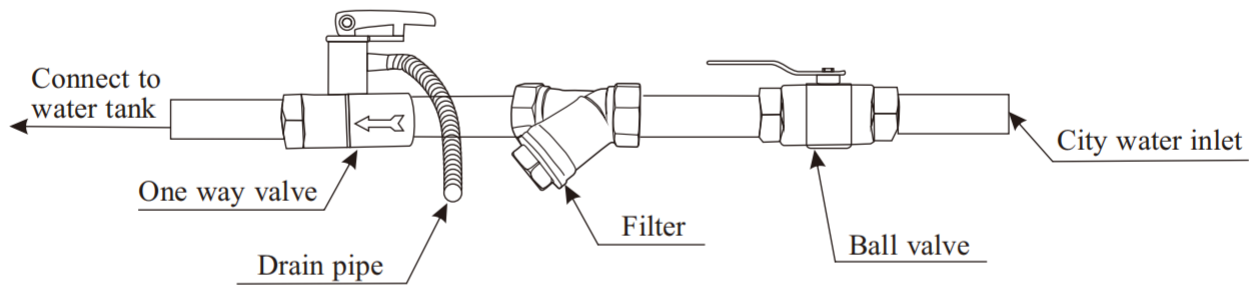

4-2. Ensuring enough water in the water circuit

4.2.1. Required amount of water

Buffer tank is to be included in the system,

It should be installed between heat pump and distribution system, in order to:

- 1) Ensure heat pump unit has stable and enough water flow rate.
- 2) Store heat to minimize fluctuation of system heating/cooling load.
- 3) Extend the water volume of distribution system for proper working of heat pump unit.

Model	Minimum amount of water (ℓ)
AW30-EVI-M	260
AW45-EVI-M	360
AW90-EVI-M	720

4-3. Inlet/Outlet pipe connection size and material

The table below shows the inlet/outlet pipe connection size

Inlet/Outlet pipe connection size

Model	Inlet pipe connection	Outlet pipe connection
AW30-EVI-M	1 1/2" Female	1 1/2" Female
AW45-EVI-M	2" Female screw	2" Female screw
AW90-EVI-M	Dn65 Flange	Dn65 Flange

5. Installation

2) Terminal block 2

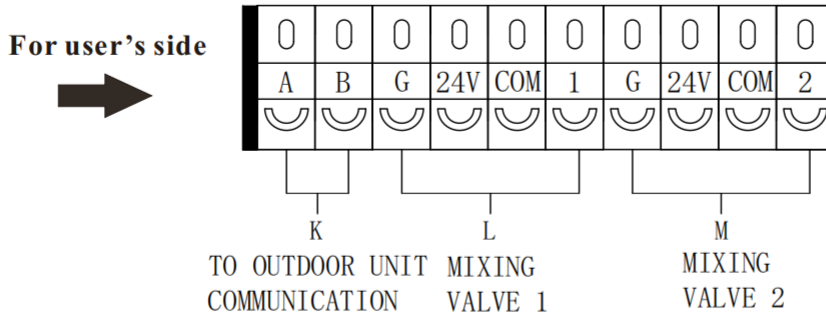

K:Indoor and outdoor communication cable

Heat pump outdoor unit AB cable need to be connected with the indoor controller AB cable for communication.

L&M:(Heating/cooling system) Mixing valve 1. (Heating/cooling system) Mixing valve 2
Waterway regulation in heating/cooling system.

This port is an active signal DC24V, which cannot be connected to active signals (such as current and voltage signals).

3) Terminal block 3

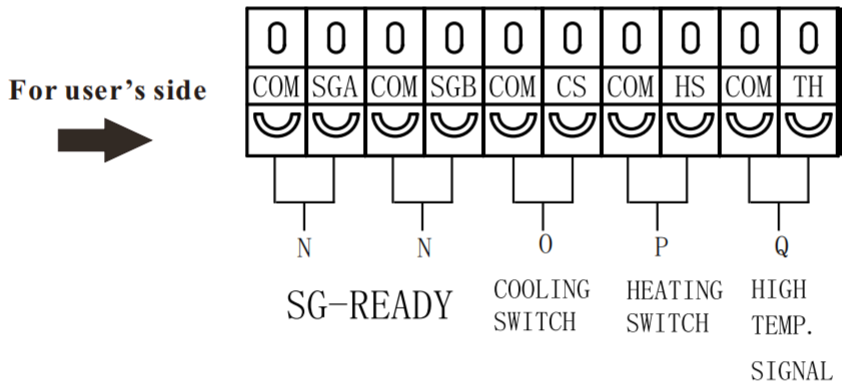

N:SG Ready linkage switch.

The SG Ready can control the heat pump switch through this port.

5. Installation

Smart Grid (SG-ready)

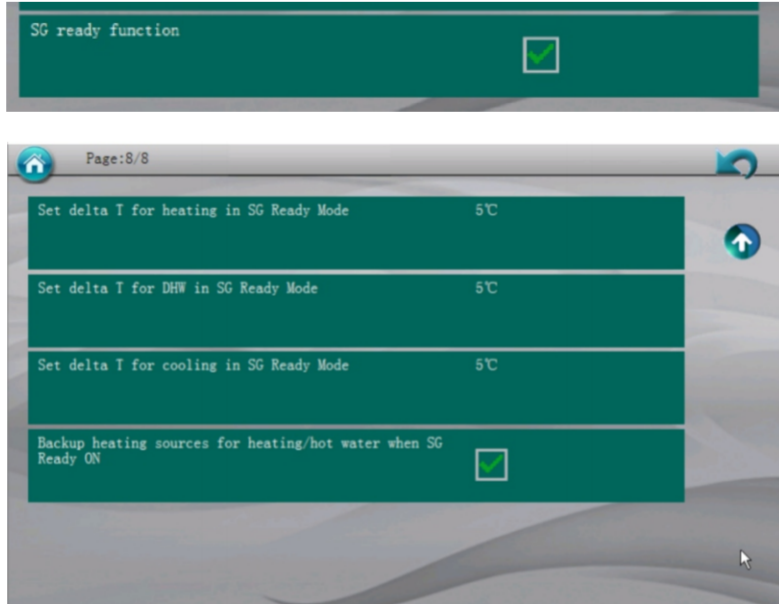

This function can only be used in power supply networks that support the “SG Ready” standard, “SG Ready” is a smart tariff management scheme, in which the heat pump can operate economically under current power grid load through digital signals provided by the electrical grid. The SG ready function is only for the heat pump heating and hot water function.

Based on two inputs to let heat pump work four different modes as recommended by Grid:

Signal 1(SGA)	Signal 2(SGB)	Operation of heat pump based on SG Ready signal
1	0	Insufficient energy from the grid necessitates a forced shutdown of the heat pump. After shutdown, the backup heater can be turned on.
0	0	The heat pump is operating normally
0	1	Grid recommends to consume more power by heat pump. The heat pump will automatically add a set temperature difference on the original set water temperature to get a new set point.
1	1	Grid produces too much power and has to be consumed by heat pump. At this time, heat pump will automatically adjust the set temperature to the maximum set temperature allowed by the system, and the electric heating can be turned on in order to consume more power from Grid.

5. Installation

- Power grid signal input “10”(SGA: closed, SGB: open), power grid overload
Insufficient energy from the grid necessitates a forced shutdown of the heat pump. After shutdown, the backup heater can be turned on.
- Power grid signal input “00”(SGA: open, SGB: open), power grid load is normal
The heat pump will run according to your settings.
- Power grid signal input “01”(SGA: open, SGB: closed), power grid power surplus
Low power surplus, Grid recommends to consume more power by heat pump. The heat pump will automatically add a set temperature difference (set in below picture) on the original set water temperature to get a new set point.
Such as: original 42 + set temp increasement 3 = new set point 45°C.
Backup heating can be turned on.

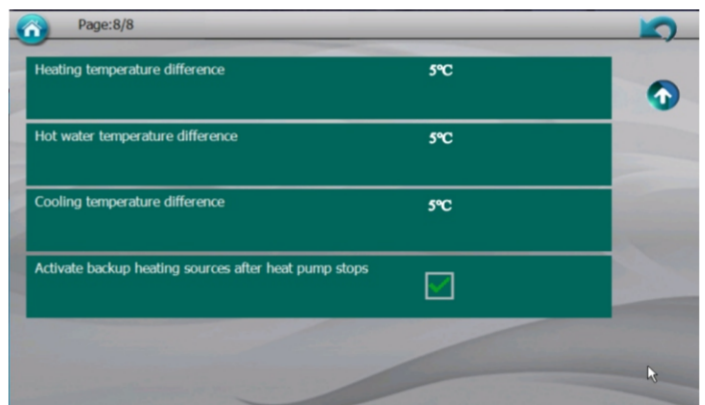
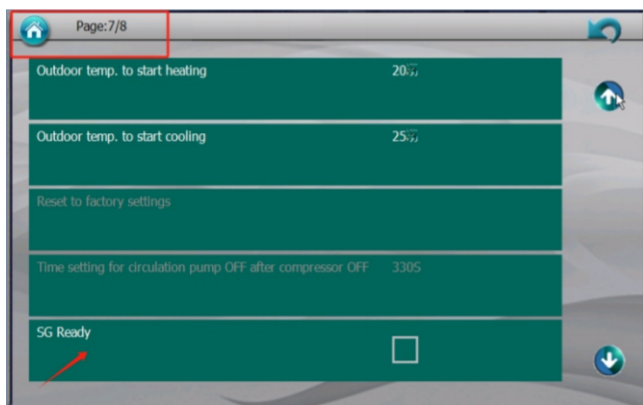
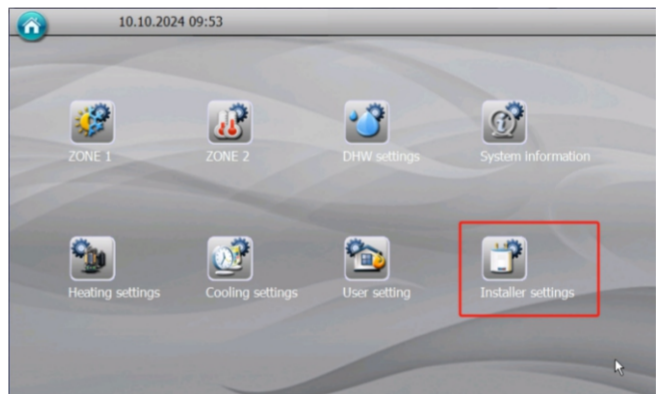
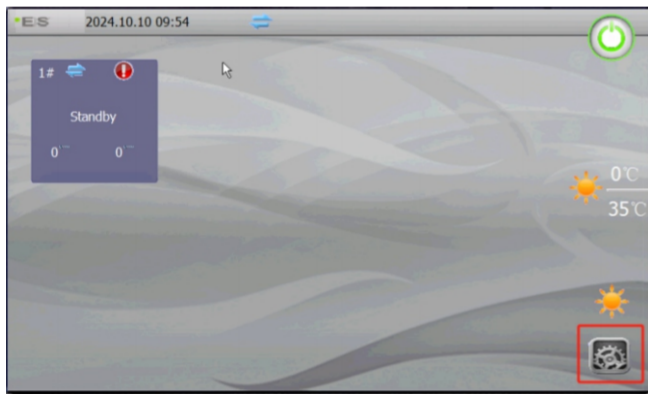

5. Installation

- Power grid signal input “11”(SGA: closed, SGB: closed), power grid power surplus
Grid produces too much power and has to be consumed by heat pump. At this time, heat pump will automatically adjust the set temperature to the maximum set temperature allowed by the system, and the electric heating can be turned on in order to consume more power from Grid. Typically, this signal is sent when there is an overproduction of electric power in the grid and it allows to store thermal energy, to be exploited when there is a demand peak.

O: Cooling signal terminal: Decide whether the heat pump starts cooling/heating according to the external signal switch.

P: Heating signal terminal: Decide whether the heat pump starts cooling/heating according to the external signal switch.

Q: High temperature signal: Set the working mode of circulating water pump in the two systems. The high temperature of system 1 or system 2 is valid (only one system can be selected at the same time.) If system 1 is selected as high temperature system, then the high temperature function of system 1 is controlled by external signals, and whether to start the high temperature function is determined by the ON/OFF signal at the high temperature signal terminal.

5. Installation

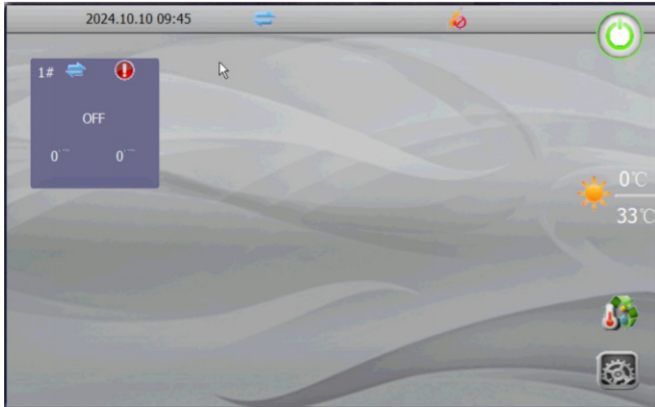

EUL

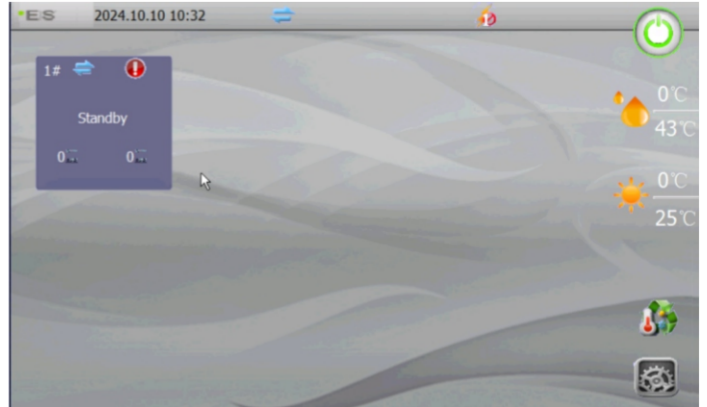

SG-Ready

AW30-EVI-M

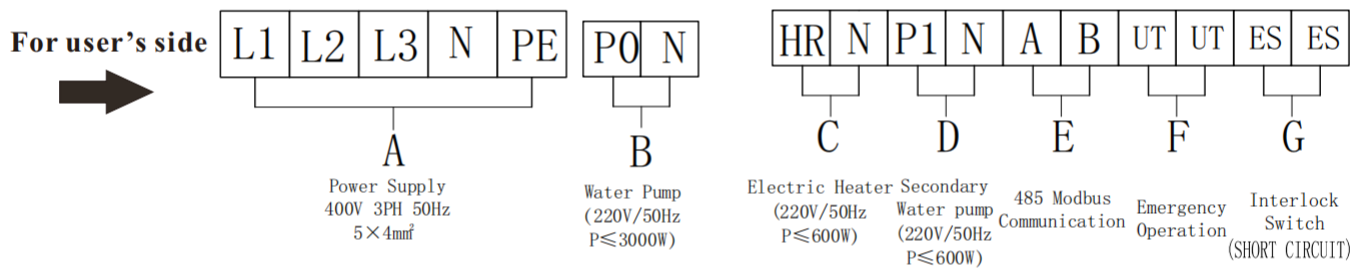

A: Power supply

It is recommended to use 5*4mm² cable as unit power supply cable for 30kW.

B: Water pump

It is a circulating water pump port, so that the circulating water pump can be controlled by heat pump. And the load power of this port cannot exceed 3000W.

C: Electric heater

If there is an external standby heater for heating, it can be connected to these ports for control by heat pump. It cannot be operated directly with load, but only as an output signal, and the load power shall not exceed 600w. If the power exceeds 600W, an additional contactor needs to be connected between heat pump and electric heater.

5. Installation

D: Secondary water pump

If there is an external water pump, it can be connected to these ports for control by heat pump. It cannot be operated directly with load, but only as an output signal, and the load power shall not exceed 600w. If the power exceeds 600W, an additional contactor needs to be connected between heat pump and water pump.

E:485 MODBUS communication for indoor and outdoor unit

Please connect cable A and B in outdoor units with cable A and B in indoor units.

F: Emergency operation

When there is a communication failure between the indoor unit and the outdoor main PCB, short circuit F to enter the emergency operation mode control.

G:Interlock switch for room thermostat.

Room thermostat can control the heat pump ON/OFF through this port.

5. Installation

AW45-EVI-M/AW90-EVI-M

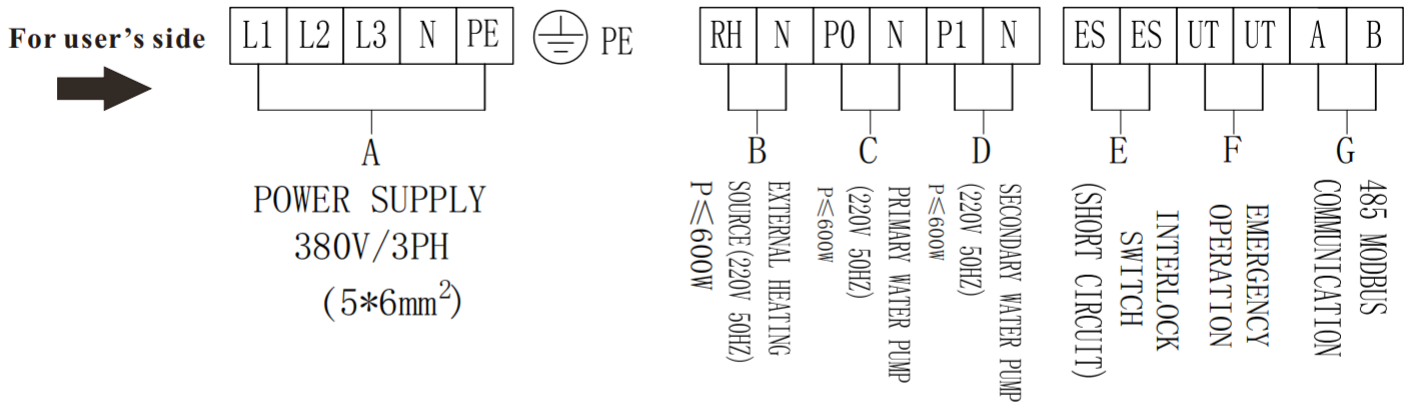

A: Power supply

For 45kW, It is recommended to use 5*6mm² cable as unit power supply cable.

For 90kW, It is recommended to use 5*6mm²*2 cables as unit power supply cable.

B: External heating source

If there is an external standby heater for heating, it can be connected to these ports for control by heat pump.

It cannot be operated directly with load, but only as an output signal, and the load power shall not exceed 600w.

If the power exceeds 600W, an additional contactor needs to be connected between heat pump and electric heater.

C: Primary water pump

It is a circulating water pump port, so that the circulating water pump can be controlled by heat pump.

It cannot be operated directly with load, but only as an output signal, and the load power shall not exceed 600w.

If the power exceeds 600W, an additional contactor needs to be connected between heat pump and water pump.

D: Secondary water pump

If there is an external water pump, it can be connected to these ports for control by heat pump. It cannot be

operated directly with load, but only as an output signal, and the load power shall not exceed 600w. If the

power exceeds 600W, an additional contactor needs to be connected between heat pump and water pump.

E: Interlock switch for room thermostat.

Room thermostat can control the heat pump ON/OFF through this port.

F: Emergency operation

When there is a communication failure between the indoor unit and the outdoor main PCB, short circuit F to enter the emergency operation mode control.

G: 485 MODBUS communication for indoor and outdoor unit

Please connect cable A and B in outdoor units with cable A and B in indoor units.

6. Wiring Design

6-1. Connect to power supply

(1) Terminal Block Arrangement

Remove the front panel of the control box, unscrew the four screws and pull the panel forward and then down.

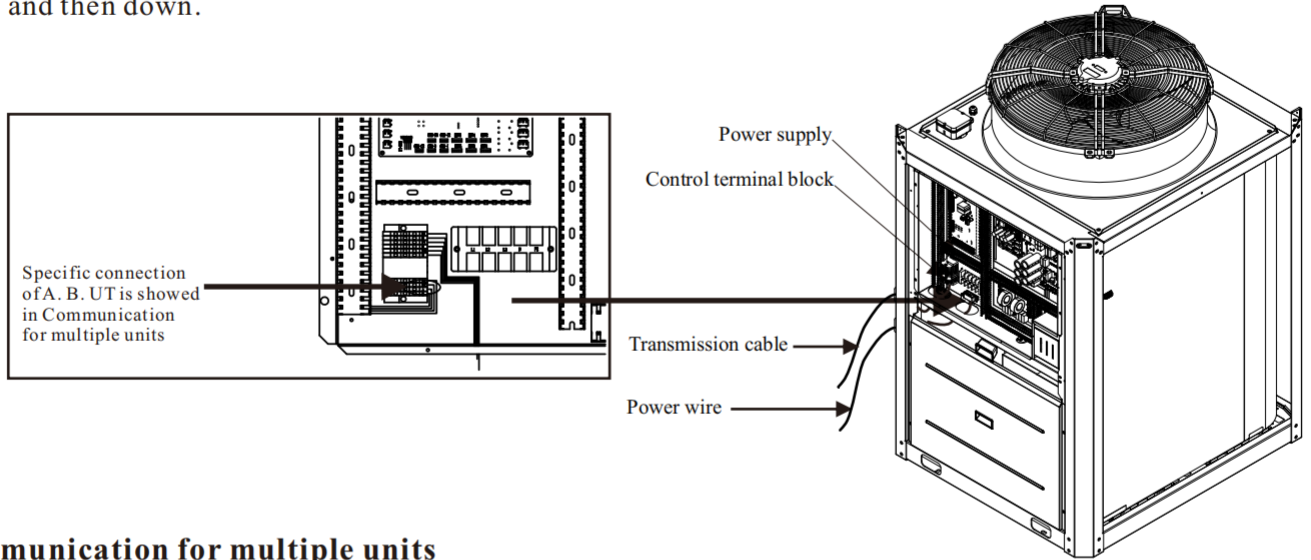

Communication for multiple units

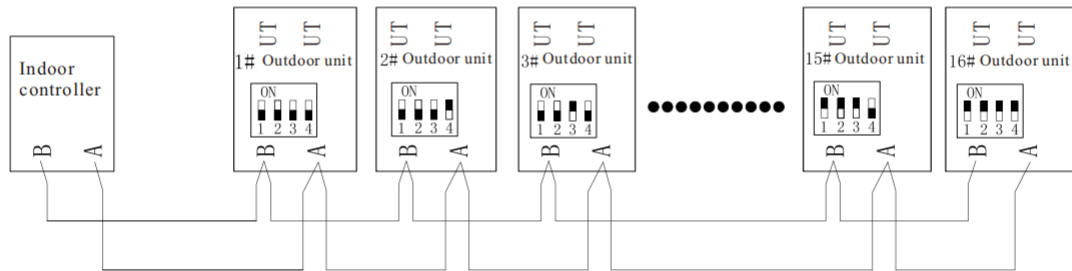

Emergency operation

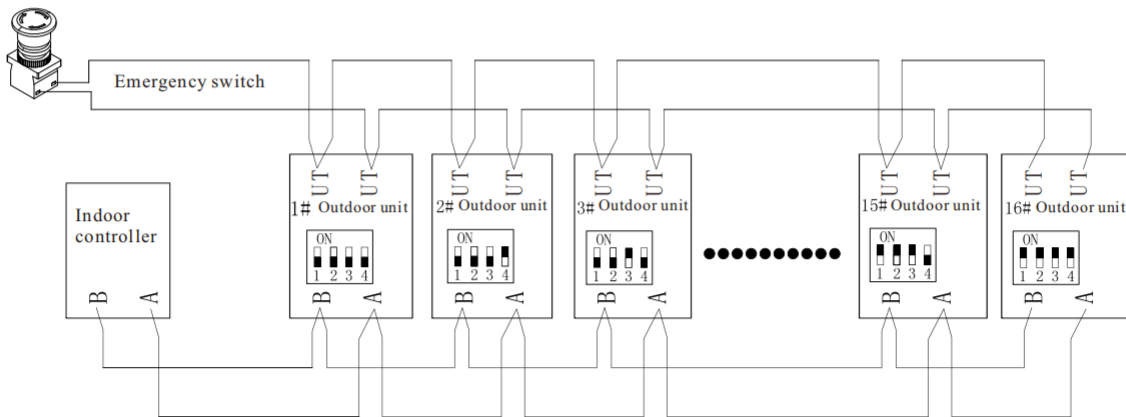

UT Terminal is open as default.

When the outdoor unit can't receive the communication signal of indoor PCB and has communication failure, turn on an external switch, and connect the UT terminals, the outdoor unit will work with preset temp. of this function.

When the ambient temperature is lower than 20 °C, the unit will start heating mode automatically, and stop when the water temperature reaches 45 °C.

When the ambient temperature is higher than 25 °C, the unit will start cooling mode automatically, and stop when the water temperature reaches 15 °C.

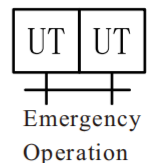

6. Wiring Design

Interlock switch

ES terminal is closed as default, and it's controlled by ON/OFF signal (no power input). When it's open, the unit can't work, when it's closed, the unit just can work. It can be used as remote control.

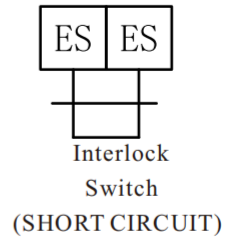

Dip switch (SW1) is used to set the system number.

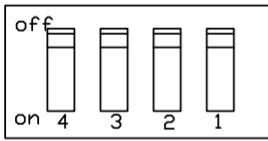

Outdoor unit main PCB--SW1

When multiple units work together, please set the dip switch as follows.

The Dip switch is detected only once when the unit is powered on. If you want to reset the dip switch, please cut off power first and reset dip switch, then power on the unit.

The value of dip switch: OFF=0,ON=1.

Dip switch setting for SW 1

System number	SW1-1	SW1-2	SW1-3	SW1-4
#1	0	0	0	0
#2	0	0	0	1
#3	0	0	1	0
#4	0	0	1	1
#5	0	1	0	0
#6	0	1	0	1
#7	0	1	1	0
#8	0	1	1	1
#9	1	0	0	0
#10	1	0	0	1
#11	1	0	1	0
#12	1	0	1	1
#13	1	1	0	0
#14	1	1	0	1
#15	1	1	1	0
#16	1	1	1	1

7. Touchscreen Panel Overview

1. Main Page

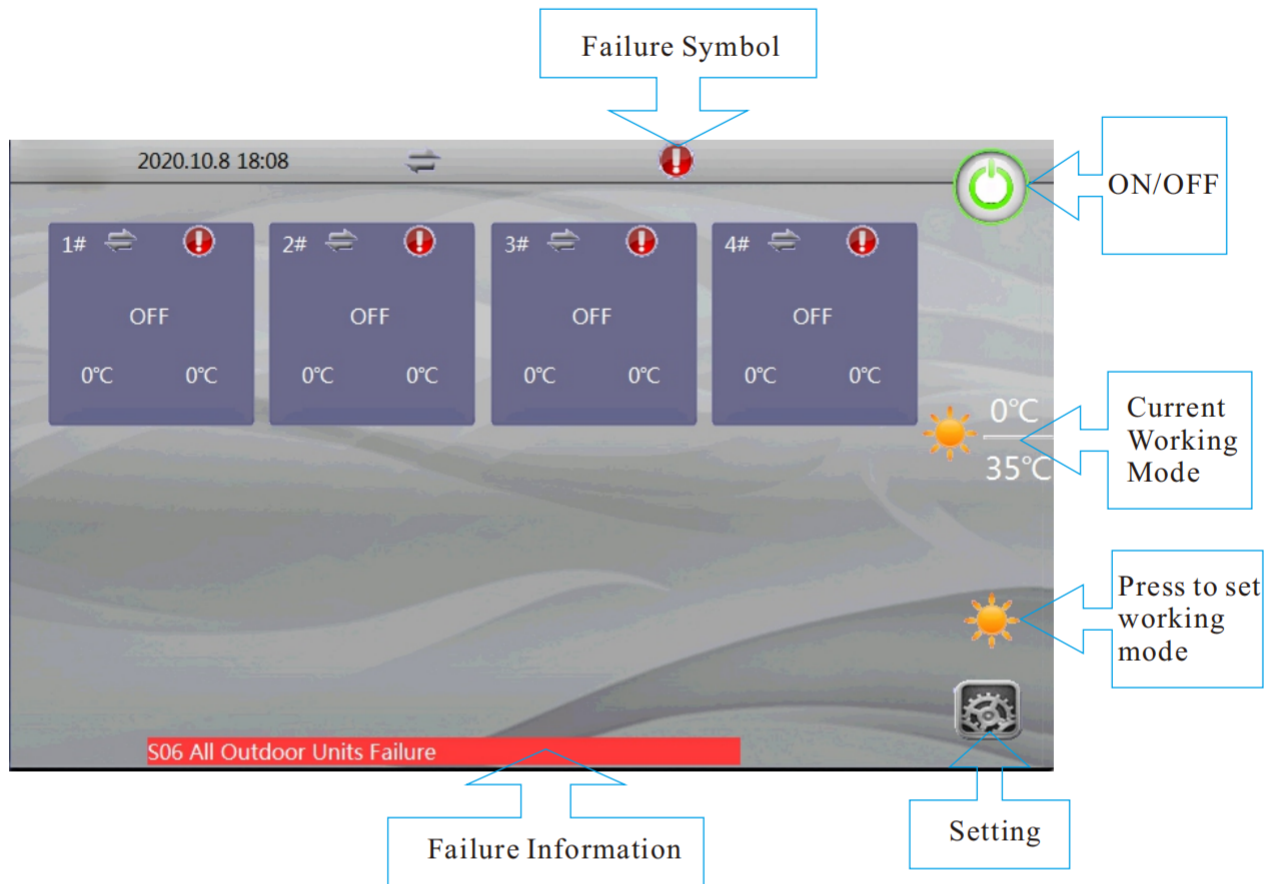

7. Touchscreen Panel Overview

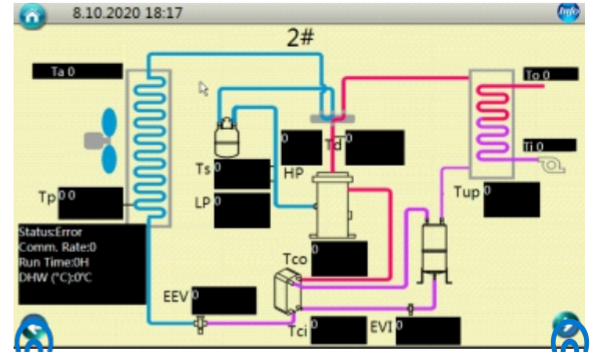
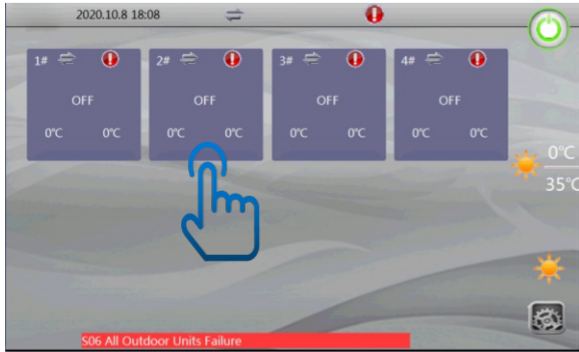

View System detailed running state.

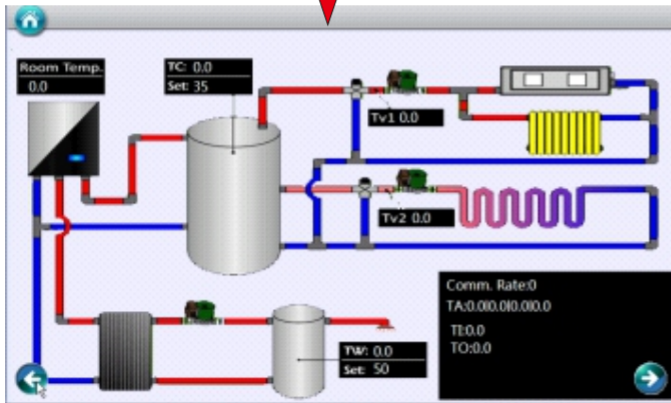
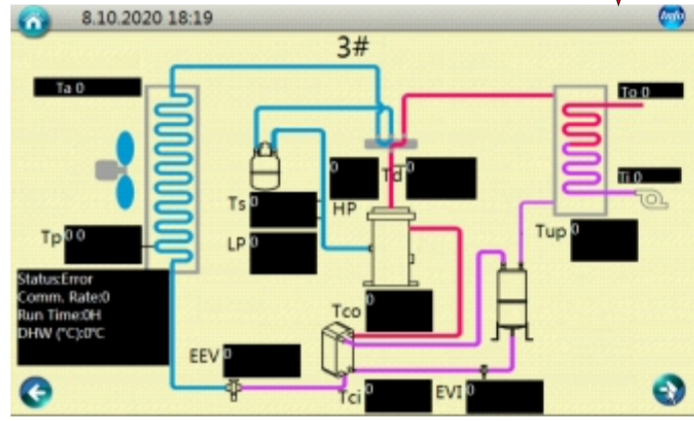
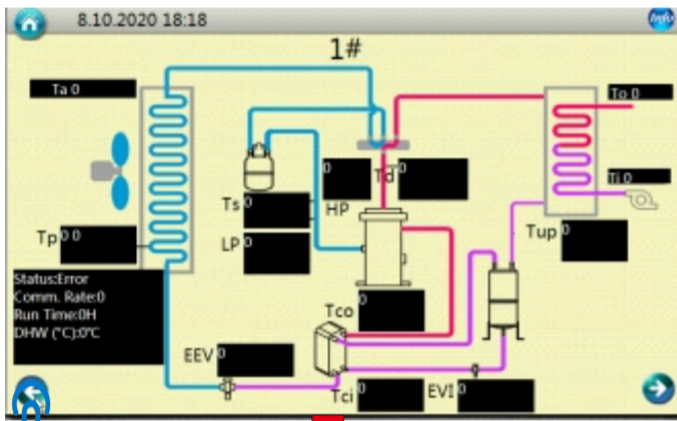

7. Touchscreen Panel Overview

1. Main Page



2. Zone 1



Click to make the settings for distribution system Zone 1.

7. Touchscreen Panel Overview

2. Zone 1

Set temp. for heating (fix flow water temperature)	40°C
--	------

If the heating curve feature is DISABLED, a fixed heating water temperature can be set via this parameter.

Set temp. for cooling (fix flow water temperature)	15°C
--	------

If the cooling curve feature is DISABLED, a fixed cooling water temperature can be set via this parameter.

High temperature limit	50°C
Low temperature limit	15°C

These two parameters should only be configured by the installer to configure a safe set temperature range for circuit 1.

Heating curve 1 (HC1)	<input type="checkbox"/>
-----------------------	--------------------------

Set whether you would like the heating curve feature to be used. If this box is left unchecked, the system can follow a fixed water temperature that is set.
If this box is checked, you will be able to create a custom heating curve by setting the parameters in next page.

7. Touchscreen Panel Overview

System 1 heating curve parallel move 0°C

Adjust the heating curve setting for heating & cooling Zone 1, based on the set heating curve (parallel move).

Water / Outdoor temp. 1 - HC1 50°C

Water / Outdoor temp. 2 - HC1 45°C

Water / Outdoor temp. 3 - HC1 40°C

Water / Outdoor temp. 4 - HC1 35°C

Water / Outdoor temp. 5 - HC1 30°C

What a custom heating curve looks like (Tsh = Set Heating Temperature, Ta = Ambient Temperature):

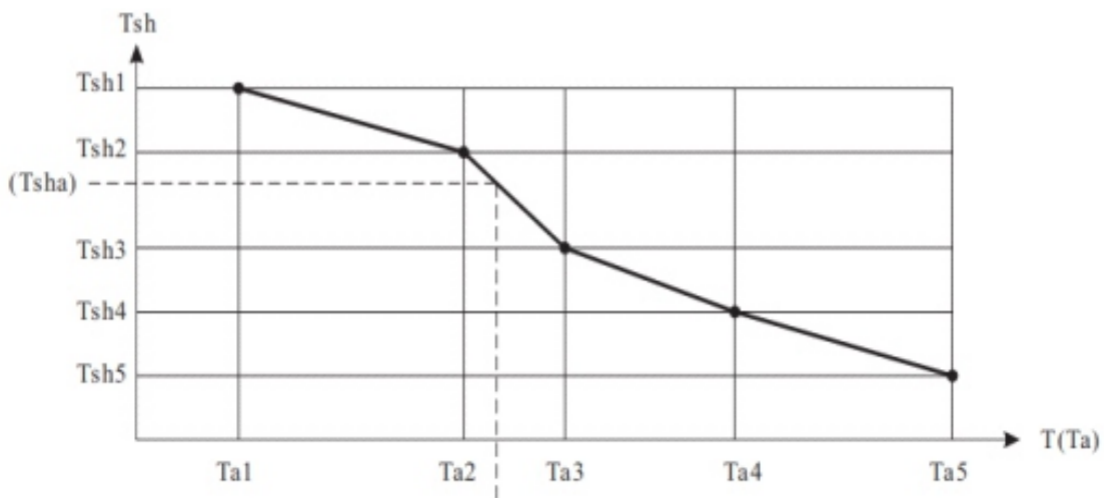

Set 5 different set water temperature, based on 5 different outdoor ambient temp values (set in “Heating Configuration” menu), to generate a heating curve set for Zone 1.

7. Touchscreen Panel Overview

Cooling curve 1 (CC1)



Activate Cooling Curve function, if needed. If not, a fixed set temperature for cooling can be set in page 1.

Water / Outdoor temp. 1 - CC1

20°C

Water / Outdoor temp. 2 - CC1

18°C

Water / Outdoor temp. 3 - CC1

15°C

Set 3 different set water temperature, based on 3 different outdoor ambient temp value (set in “Cooling Configuration” menu), to generate a cooling curve set for Zone 1.

7. Touchscreen Panel Overview

Mixing valve ZONE 1

Check this box if a mixing valve is connected. If not, leave this unchecked.

P1 for heating operation

P1 for cooling operation

P1 with high temp. demand

P1 Timer function

These parameters are used for setting the functionalities of the external circulation pumps P1 for Zone 1.

If Zone 1 is used for heating operation, “P1 for heating operation” should be activated.

If Zone 1 is used for cooling operation, “P1 for cooling operation” should be activated.

If Zone 1 needs to work when system get a “high temp. demand” signal only (or say this is a high temp. circuit), “P1 with high temp. demand” should be activated.

If Zone 1 should work only in the set time period, “P1 Timer function” should be activated.

7. Touchscreen Panel Overview

P1 Timer

If “P1 Timer function” is activated, P1 will only work in the time period set in “P1 Timer” menu.

P1 Interval working mode	<input type="checkbox"/>
P1 ON duration	1min
P1 OFF duration	6min

If “buffer tank” menu (see in menu “System Configuration) is activated, P1 will always work if system had demanding, so to circulate the energy between buffer tank and distribution system.

If “buffer tank” menu is not activated, P1 should stop working after compressor stops.

If P1 needs to work occasionally so to read the temperature in the system, “P1 Interval working mode” should be activated. After activated, P1 will work for “P1 ON duration” time everytime, after it stops for “P1 OFF duration”.

7. Touchscreen Panel Overview

3. Zone 2



Click to make the settings for distribution system Zone 2.

Zone 2	<input type="checkbox"/>
--------	--------------------------

If you need a dual water temperature setting, please tick this item.

Set temp. for heating (fix flow water temperature)	45°C
Set temp. for cooling (fix flow water temperature)	20°C

If the heating/cooling curve feature is DISABLED, a fixed heating/cooling water temperature can be set via this parameter.

High temperature limit	50°C
Low temperature limit	15°C

These two parameters should only be configured by the installer to configure a safe set temperature range for circuit 1.

7. Touchscreen Panel Overview

Heating curve 2 (HC2)



Set whether you would like the second heating curve feature to be used. If this box is left unchecked, the system can follow a fixed water temperature that is set; If this box is checked, you will be able to create a custom heating curve by setting the parameters following.

System 2 heating curve parallel move

0°C

Adjust the heating curve setting for heating & cooling Zone 1, based on the set heating curve (parallel move).

Water / Outdoor temp. 1 - HC2

50°C

Water / Outdoor temp. 2 - HC2

45°C

Water / Outdoor temp. 3 - HC2

40°C

Water / Outdoor temp. 4 - HC2

35°C

Water / Outdoor temp. 5 - HC2

30°C

What a custom heating curve looks like (Tsh = Set Heating Temperature, Ta = Ambient Temperature):

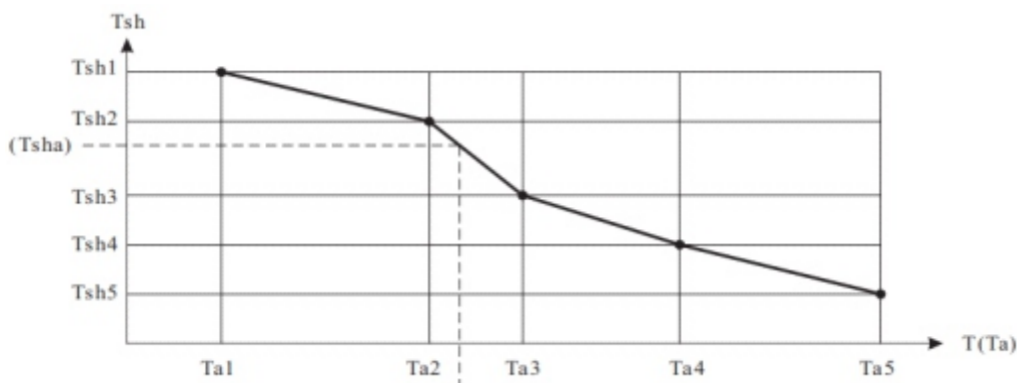

Set 5 different set water temperature, based on 5 different outdoor ambient temp values (set in “Heating Configuration” menu), to generate a heating curve set for Zone 2.

7. Touchscreen Panel Overview

Cooling Curve 2 (CC2)



Activate Cooling Curve 2 function, if needed.
If not, a fixed set temperature for cooling can be set in page 11.

Water / outdoor temp. 1 - CC2

20°C

Water / outdoor temp. 2 - CC2

18°C

Water / outdoor temp. 3 - CC2

15°C

Set 3 different set water temperature, based on 3 different outdoor ambient temp values (set in “Cooling Configuration” menu), to generate a cooling curve set for Zone 2.

7. Touchscreen Panel Overview

Mixing valve ZONE 2	<input type="checkbox"/>
---------------------	--------------------------

Check this box if a mixing valve is connected. If not, leave this unchecked.

P2 for heating operation	<input type="checkbox"/>
P2 for cooling operation	<input type="checkbox"/>
P2 with high temp. demand	<input type="checkbox"/>
P2 Timer function	<input type="checkbox"/>
P2 Timer	

These parameters are used for setting the functionalities of the external circulation pumps P2 for Zone 2.

If Zone 2 is used for heating operation, “P2 for heating operation” should be activated.

If Zone 2 is used for cooling operation, “P2 for cooling operation” should be activated.

If Zone 2 needs to work when system get a “high temp. demand” signal only (or say this is a high temp. circuit), “P1 with high temp. demand” should be activated.

If Zone 2 should work only in the set time period, “P2 Timer function” should be activated.

If “P2 Timer function” is activated, P2 will only work in the time period set in “P2 Timer” menu.

7. Touchscreen Panel Overview

P2 Interval working mode	<input type="checkbox"/>
P2 ON duration	1
P2 OFF duration	6

If “buffer tank” menu (see in menu “System Configuration) is activated, P2 will always work if system had demanding, so to circulate the energy between buffer tank and distribution system. If “buffer tank” menu is not activated, P2 should stop working after compressor stops. If P2 needs to work occasionally so to read the temperature in the system, “P2 Interval working mode” should be activated. After activated, P2 will work for “P2 ON duration” time everytime, after it stops for “P2 OFF duration”.

4. D.H.W (Domestic hot water)



Click to check the information of the system.

DHW Setpoint	50°C
--------------	------

This option sets the upper limit for the desired sanitary hot water temperature.

7. Touchscreen Panel Overview

DHW Restart ΔT

5°C

The system begins working in DHW again once the temperature drops below the set temperature minus this ΔT temperature.

DHW Timer function



Activate or not, the Timer function for DHW mode. Once activated, unit is only allowed to work in DHW mode in set time period, with set temperature.

7. Touchscreen Panel Overview

DHW Timer 1	
DHW Set temp. - Timer 1	50°C
DHW Timer 2	
DHW Set temp. - Timer 2	51°C
DHW Timer 3	
DHW Set temp. - Timer 3	52°C

Three groups of timer setting and temperature setting, for DHW mode, if needed.

Unit will only work in DHW mode in the set timer ON period. In conflict time period, it will take higher set value as the set value for this time period for DHW mode.

DHW Pump interval working mode	<input type="checkbox"/>
DHW Pump ON duration	1min
DHW Pump OFF duration	6min

After reach the set temperature for DHW, DHW pump should stop working, till water temperature drops down below DHW restart set point.

However, if DHW pump needs to circulate water occasionally to read the water temperature, “DHW Pump interval working mode” should be activated, which will make DHW pump work for “DHW Pump ON duration” time after stops for every “DHW Pump OFF duration” time.

7. Touchscreen Panel Overview

5. System information

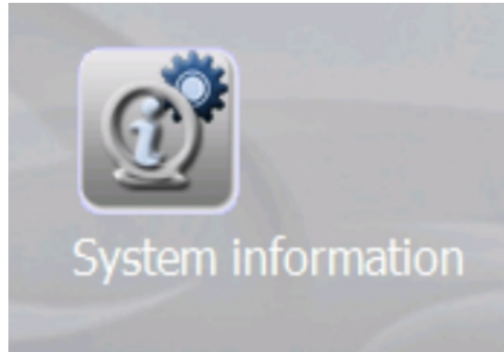

Click to check the information of the system.

6. Heating settings

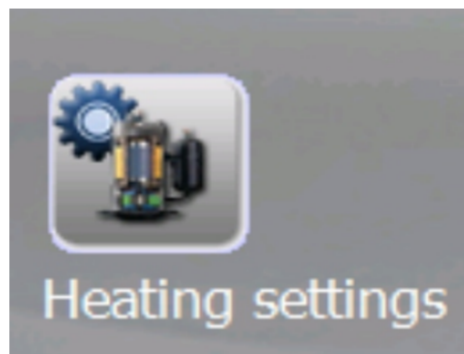

Click to set basic setting for heating operation.



This is to configure a difference in temperature at which the unit restarts, after stops due to reach the set temp.



Activate or not, the Timer function for heating mode. Once activated, unit is only allowed to work in heating mode in set time period, with set temperature.

7. Touchscreen Panel Overview



Three groups of timer setting and temperature setting, for heating mode, if needed.

Unit will only work in heating mode in the set timer ON period. In conflict time period, it will take higher set value as the set value for this time period for heating mode.

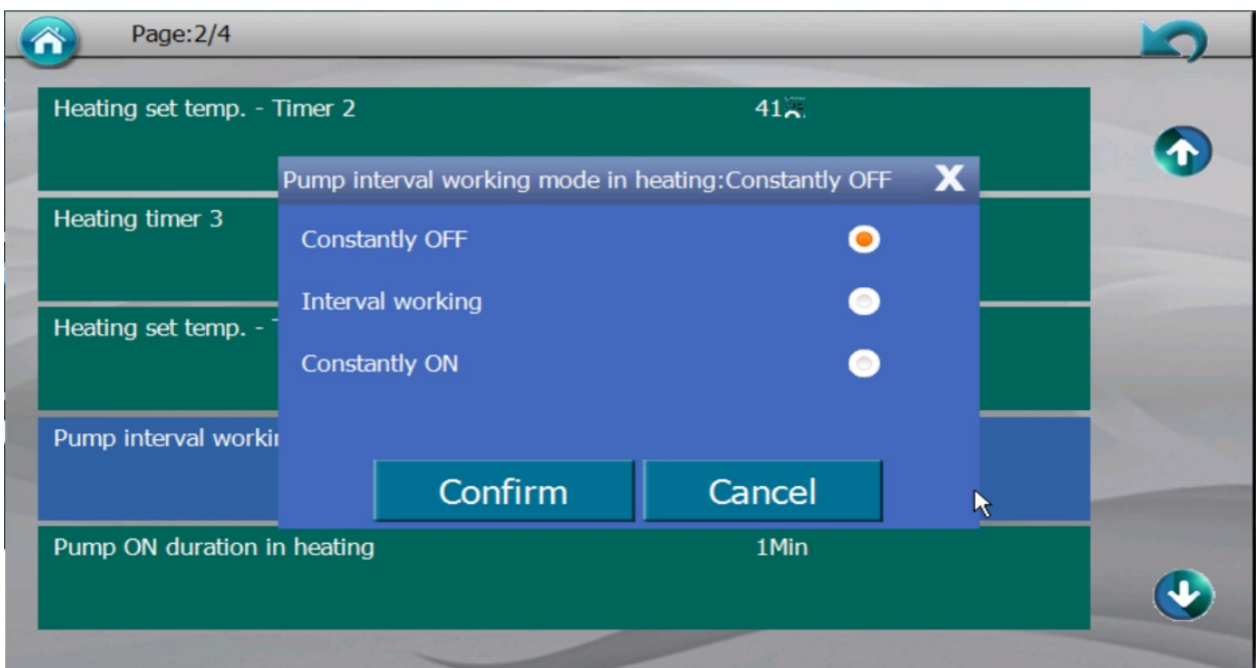

7. Touchscreen Panel Overview

This is setting for unit circulation pump.

If this function is not activated, unit circulation pump will keep on working.

If this function is activated, unit circulation pump will stop working after compressor stops, but work for “Pump ON duration in heating” time after stops for every “Pump OFF duration in heating” time.

Outdoor temp. 1 - HC	-25°C
Outdoor temp. 2 - HC	-15°C
Outdoor temp. 3 - HC	-5°C
Outdoor temp. 4 - HC	5°C
Outdoor temp. 5 - HC	15°C

What a custom heating curve looks like (T_{sh} = Set Heating Temperature, T_a = Ambient Temperature):

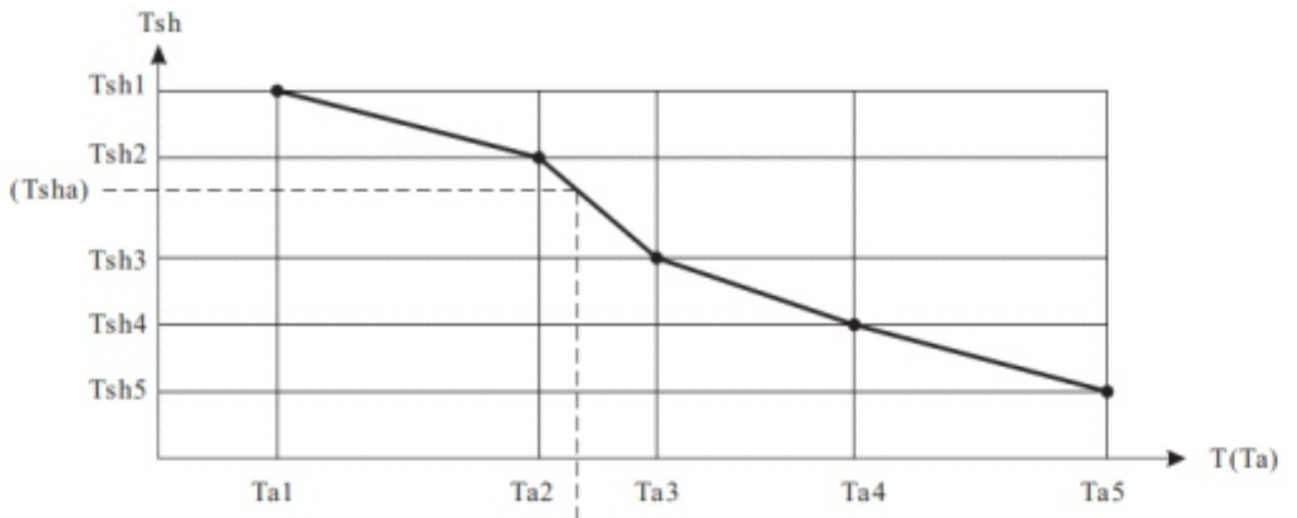

Set 5 different outdoor ambient temperature value, for 5 different water temp set value (set in “Zone 1” menu), to generate a heating curve set for Zone 1.

7. Touchscreen Panel Overview

7. Cooling settings



Click to set basic setting for cooling operation.

Cooling restart ΔT

2°C

This is to configure a difference in temperature at which the unit restarts, after stops due to reach the set temp.

Cooling timer function



Activate or not, the Timer function for cooling mode. Once activated, unit is only allowed to work in cooling mode in set time period, with set temperature.

7. Touchscreen Panel Overview

Cooling timer 1	
Cooling set temp. - Timer 1	15°C
Cooling timer 2	
Cooling set temp. - Timer 2	16°C
Cooling timer 3	
Cooling set temp. - Timer 3	17°C

Three groups of timer setting and temperature setting, for cooling mode, if needed.

Unit will only work in cooling mode in the set timer ON period. In conflict time period, it will take higher set value as the set value for this time period for cooling mode.

7. Touchscreen Panel Overview

Pump interval working mode in Cooling	<input type="checkbox"/>
Pump ON duration in cooling	1min
Pump OFF duration in cooling	6min

This is setting for unit circulation pump.

If this function is not activated, unit circulation pump will keeps on working.

If this function is activated, unit circulation pump will stop working after compressor stops, but work for “Pump ON duration in heating” time after stops for every “Pump OFF duration in heating” time.

Outdoor temp. 1 - CC	16°C
Outdoor temp. 2 - CC	26°C
Outdoor temp. 3 - CC	36°C

Set 3 different set water temperature, based on 3 different outdoor ambient temp values (set in “Cooling Configuration” menu), to generate a cooling curve set for Zone 2.

7. Touchscreen Panel Overview

8. User settings

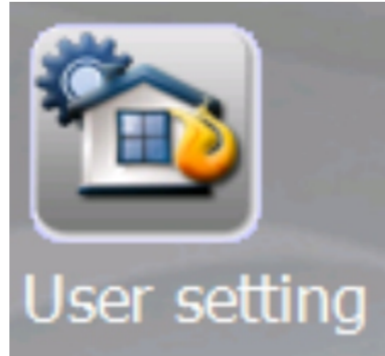

Click to set for more advanced setting.

Permission level	End User
------------------	----------

For the safety purpose, some parameters can only be adjusted under the installer's permission level. This can be configured within this menu, by inputting a correct password.

Control panel backlight light	Always ON
-------------------------------	-----------

Set a time limit for the touchscreen backlight. You can also set it to always be on. To prolong the life span of the touch display, It is recommended to set the control backup light to "OFF after 3 minutes".

Language	English
----------	---------

For setting the system language.

Time	16.10.2020 08:39
------	------------------

For setting the system clock date and time.

7. Touchscreen Panel Overview

ECO Operation

DHW ECO operation	<input type="checkbox"/>
Outdoor temp. to start DHW ECO operation	-10°C

Heat Pump always try to finish its DHW work as soon as possible, to concentrate in heating or cooling operation. However, when outdoor ambient temperature is higher than a certain value, unit capacity would be more than enough, if it still works in high speed. Thus it would be wiser to lower the running speed at this moment for DHW. By activating this menu, compressor speed will be lowered to 50% for DHW production when outdoor ambient temperature is higher than set value “Outdoor temp. to start DHW ECO operation”, for better efficiency.

Heating ECO operation	<input type="checkbox"/>
Outdoor temp. to start heating ECO operation	-15°C

Heat pump efficiency drops when outdoor air temperature drops. If outdoor air temperature is lower than a certain value, may more economic to use the external Heating Backup Heater(HBH) heating source for heating. If so, by activate "DHW ECO Operation" and set a proper setting of "Ambient Temperature to Start Heating ECO Operation", unit will stop compressor from working for heating but gives a "ON(close)" signal to external HBH heater when actual outdoor air temperature is lower than the set value.

7. Touchscreen Panel Overview

Vacation Mode

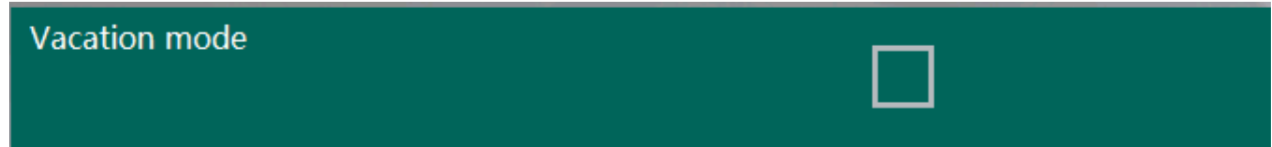

During periods when users are away from home for extended lengths of time, this mode can serve to reduce the preset temperatures for both sanitary hot water, as well as for house heating, in order to save energy.

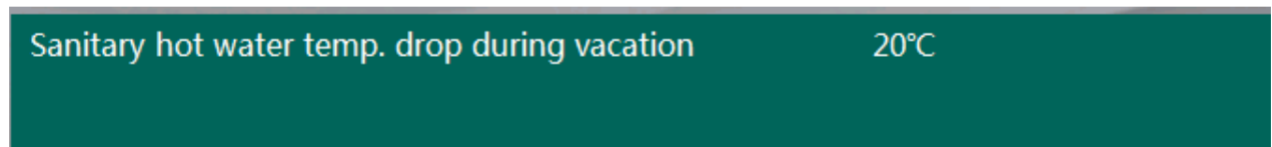

Use this parameter to set the desired drop in temperature of sanitary hot water for when the vacation mode function is active. This number is based on the standard domestic hot water value set.

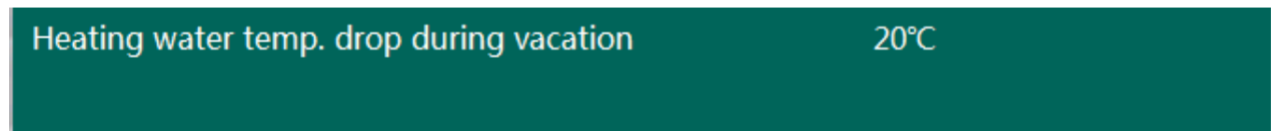

Use this parameter to set the desired drop in temperature of the water used for heating for when the vacation mode function is active. This number is based on the standard heating value set.



Set the date for when vacation mode begins.



Set the date for when vacation mode ends.

7. Touchscreen Panel Overview

Reduce Mode & Quiet Operation

Reduced mode

During periods of low demand, such as typical sleep or working hours, the system can operate based on a reduction of the set heating value in order to deliver better efficiency and cost savings.

Reduced mode - Temp. drop / rise 8°C

This parameter can be used to set the amount of temperature drop (in heating modes) or temperature rise (in cooling modes) in Reduced Mode. This drop/rise is based on the standard temperature that is set at the time of the setpoint operation.

Reduced mode - Timer

This parameter can be used to set the schedule of when the heating setpoint reduction can take place. Each day of the week is individually customizable with separate time blocks. The feature will only work during the times that are set here.

Quiet operation

Turn On or OFF Quiet operation, for a better noise level during the set time period.

Quiet operation - Max allowable temp. drifting 5°C

Quiet operation - Timer

When the unit is in quiet mode, its functional output may decrease due to both the fan and compressor operating at a restricted speed. Therefore, if the temp. begins to fluctuate outside of the ΔT value set here, the unit will automatically exit the quiet operation mode to ensure that the allowable temperatures are delivered.

This parameter can be used to set the scheduling of when the quiet operation mode takes place.

7. Touchscreen Panel Overview

Anti-legionella

Anti-legionella function	<input type="checkbox"/>
--------------------------	--------------------------

If the user will be drawing hot water directly from the hot water tank (HWT), then it will be required to heat the water within the tank to over 60°C at least once a week, for legionella prevention purposes. Please follow all local regulations regarding the proper usage of this function.

Anti-legionella - Setpoint	75°C
----------------------------	------

This parameter can be used to set the value at which the system will heat the water to in order to achieve proper legionella prevention. Please follow all local regulations regarding this practice.

Anti-legionella - Duration	30Min
Anti-legionella - Max. running time	180Min

Set the duration of the anti-legionella operation. The time entered here will be how long the unit will keep the temperature set “Anti-legionella-Set point”, in order to ensure that all bacteria in the shower water tank have been killed.

Set an absolute end time (operational ceiling limit) for the anti-legionella function, even if it has not been fully completed.

Anti-legionella - Starting time

This parameter can be used to set the times and days of the week that the operation takes place.

7. Touchscreen Panel Overview

Room Temp. Effect on Curve

Room temp. effect on heating curve



If activated this function, it will compare the current room temperature with below set “Ideal Room Temperature”, and deduct the difference in the current value set for water temperature, in order to compensate the gap, in both HEATING and COOLING modes.

Ideal room temp. in heating

20°C

Set the ideal room temperature in heating operation.

Ideal room temp. in cooling

26°C

Set the ideal room temperature in cooling operation.

7. Touchscreen Panel Overview

Internet Connection--WI-FI

Internet connection	Cable internet
Remote settings	<input checked="" type="checkbox"/>
Connection to server	Disconnected
Connection to router	Disconnected
MAC	FF-FF-FF-FF-FF-FF
IP address	127.0.0.1
SSID	
Password	

Information of unit internet connection.

Server address	www.myheatpump.com
Service port	18899

7. Touchscreen Panel Overview

Floor Curing

Floor curing	<input type="checkbox"/>
Floor curing current stage	0
Floor curing current stage running duration	0H
Floor curing current stage set temperature	0°C
Floor curing current stage valid running duration	0H
Floor curing total running duration	0H
Highest water temp. in floor curing operation	0°C

After initial installation, or when a long period of unit inactivity has passed, the floor-heating system may have become damp within the concrete. Most of the heating capacity of the heat pump unit is consumed to dry up and evaporate the water in the concrete. The floor curing function is used to dry up the floor, to ensure the safe operation of the heat pump system.

Floor Curing Toggle this feature ON or OFF. This feature and the settings that follow will only be active if the checkbox is marked. When floor curing function is activated, it will run automatically the pre-set program, until the complete function is finished successfully (if not, a warning information will be shown on the screen. All the running data during the process will be recorded and can be viewed.

7. Touchscreen Panel Overview

9. Installer settings

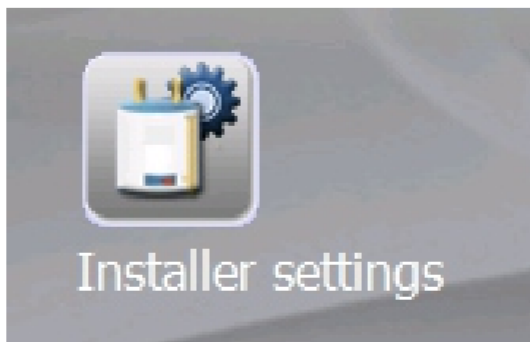

Click to set basic setting for D.H.W

Heat pump cascade quantity	4
----------------------------	---

Set the system cascade unit quantity.

Sanitary hot water	<input checked="" type="checkbox"/>
Heating	<input checked="" type="checkbox"/>
Cooling	<input checked="" type="checkbox"/>

Set the working modes need for this installation.

Load saved settings
Save settings

Used by the installer to save his setting, and load the saved setting.

7. Touchscreen Panel Overview

Electrical Utility Lock

P1/P2 operation during anti-freezing



Unit has anti-freezing protection. Set whether P1/P2 should be also activated, during anti-freezing operation.

Electrical utility lock



Electrical utility lock signal

Normally Close

Some electricity companies offer a special rate to households that lower their power consumption during predetermined “peak times”. During these times, companies will send a signal to all houses, to receive feedback signals on whether or not certain electrical equipments are ON or OFF. Activate this function, and set the signal type according to local regulation.

7. Touchscreen Panel Overview

HBH(Heating Backup Heater)



Our system can control two external heating source. One is default to have, called “AH”, Auxiliary Heater. One is an option, called HBH. Use this menu to set whether system has two-stage external heating source.

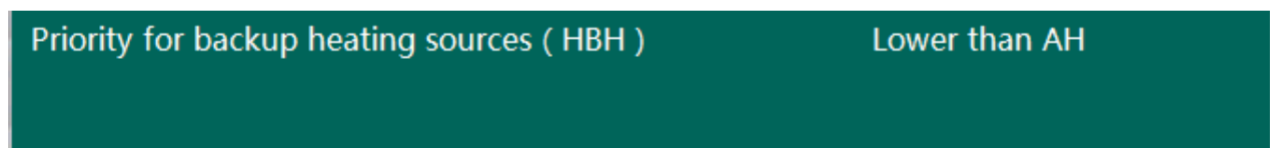

This provides options regarding the priority enforcement of HBH compared against the unit's AH. If the heat pump can't provide enough power when the system is operating in heating mode, it will turn on the AH or HBH automatically, according to which have higher priority. If the output power is still not enough after the AH or HBH has begun working, then the unit will turn on the lower priority backup heating source as well.

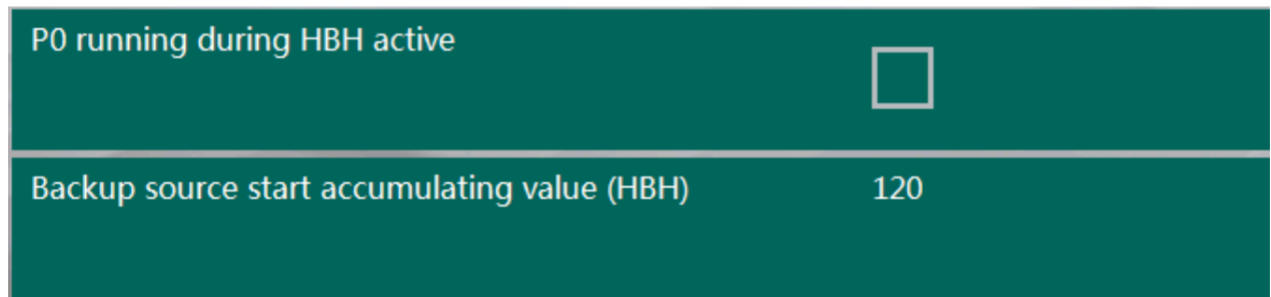

Set whether unit circulation pump need to work, when HBH is working.

This is used to adjust how quickly the backup heating sources activate when the heat pump cannot provide sufficient power when in heating mode. The greater the value set, the longer it takes for the backup heating sources to begin working when the heat pump’s capacity is not enough.

7. Touchscreen Panel Overview

HWTBH = Hot Water Tank Backup Heater

Backup heating source for sanitary hot water

Set whether the system contains a HWTBH. Toggle this feature ON or OFF.

Priority for backup heating sources (HWTBH) Lower than AH

This provides options regarding the priority enforcement of HWTBH compared against the unit's AH. If the heat pump can't provide enough power when the system is operating in hot water mode, it will turn on the AH or HWTBH automatically, according to whichever is set to have the higher priority. If the output power is still not enough after the AH or HWTBH has begun working, then the unit will turn on the lower priority backup heating source as well.

P0 running during HWTBH active

Set whether unit circulation pump need to work, when HWTBH is working.

Water temperature rise reading interval (HWTBH) 5min

The purpose of this parameter is to set the frequency of checks on the increase in temperature when the system is working in DHW mode. If the temperature is increasing too slowly during the interval of time set here, then the unit will activate other heating sources for the DHW operation. The smaller the value set, the more likely the unit is to activate AH or HWTBH for a faster DHW heating experience.

7. Touchscreen Panel Overview

Others

Emergency operation	<input checked="" type="checkbox"/>
---------------------	-------------------------------------

This parameter sets whether the unit should turn on the backup heating system automatically when the heat pump fails to work. Toggle this feature ON or OFF.

Note: If this function is activated, then all users should be occasionally checking the working status of the heat pump unit, to ensure full functionality.

Diverting valve switching time	1Min
Diverting valve - power on time	Always power ON

Configure how many minutes are spent switching (from start to finish) between the sanitary hot water and the heating/cooling circuit, and the way of powering by the motorized diverting valve.

Note: This parameter must comply with the capabilities of the motorized diverting valve, else the unit may not be able to work properly due to an insufficient water flow rate.

Air purge - heating/cooling circuit	<input type="checkbox"/>
Air purge - DHW circuit	<input type="checkbox"/>

Used for air purging. Once activated, unit and external pump will be turned ON, while the diverting valve will be switched to such circuit for air purging.

Mode signal output	OFF
Mode signal type	Normally Close

Activate to output a signal during set working period, if needed, for controlling other devices.

Buffer tank	<input type="checkbox"/>
-------------	--------------------------

Set whether the system has buffer tank. It will affect the working of external pump P1/P2.

7. Touchscreen Panel Overview

Sensor calibration

Heating / cooling stop - water ΔT 2°C

This is to configure a difference in temperature at which the unit will stop further operation.

DHW / Heating water temp. compensate type No Compensate

Sensor calibration function.

DHW / Heating water temp. compensate value 0°C

DHW/Heating Sensor calibration value.

Cooling water temp. compensate value 0°C

Cooling Sensor calibration value.

7. Touchscreen Panel Overview

Heating / cooling switch	Outdoor temp.
Outdoor temp. to start heating	18°C
Outdoor temp. to start cooling	20°C

This function's purpose is to set the conditions under which the unit starts cooling or heating automatically, according to:

- If set to “Ambient Temp.” the system will automatically choose to enter a cooling or heating operation based on the outdoor ambient temperature, compared with the parameters set in below menus.
- If set to “External Signal Control”, an external room thermostat or central control system in the building can control the cooling or heating requirements by connecting it to the respective signal ports. The signals are binary (simple 0 or 1). If the cooling port receives the signal, the system switches to cooling. The same goes for heating. Otherwise, the system will stay in standby mode.
- If set to “Ambient Temp. + External Signal Control”, the unit will take both the ambient temperature and the external signal into consideration for the heating or cooling mode selection. Note: If the parameter is set to OFF, the auto-switch function will not be active. If this is the case, ensure that the Heating Water Circuit and Cooling Water Circuit are not set to ON simultaneously, as the system cannot determine the actual requirements due to mode conflict. To avoid mode conflict when in “External Signal Control” mode, please ensure that the external signal will not be activated at the cooling and heating ports at the same time.

Reset all setting to factory default setting.

Reset to factory settings

7. Touchscreen Panel Overview

SG-ready

Tips: SG-ready (short for smart grid ready)

This function can respond to defined external control signals by smart grid, "SG Ready" is a smart tariff management scheme, This function can respond to defined external signals and adjusts heat pump's operation according to the price signals and status of the grid, which allows the heat pump to support the grid, have a lower carbon footprint and be more cost-effectiveness to operate.

Based on two inputs to let heat pump work four different modes as recommended by Grid:

SGA	SGB	SG Ready operation requirement
1	0	Insufficient energy from the grid necessitates a forced shutdown of the heat pump. After shutdown, the backup heater can be turned on.
0	0	The heat pump is operating normally.
0	1	Grid recommends to consume more power by heat pump. The heat pump will automatically add a set temperature difference on the original set water temperature to get a new set point.
1	1	Grid produces too much power and has to be consumed by heat pump. At this time, heat pump will automatically adjust the set temperature to the maximum set temperature allowed by the system, and the electric heating can be turned on in order to consume more power from Grid.

Mode 1 – Blocked operation: Power grid signal input “10”(SGA: closed, SGB: open), power grid overload Insufficient energy from the grid necessitates a forced shutdown of the heat pump. The operation for the heat pump is blocked for a maximum of two hours per day.

Mode 2 – Normal operation: Power grid signal input “00”(SGA: closed, SGB: open), power grid load is normal

The heat pump will run according to your settings.

Mode 3 – Encouraged operation: Power grid signal input “01”(SGA: closed,SGB:closed), power grid power surplus

Low power surplus, Grid encourage to increase more electricity consumption for heat pump. And backup heater can be turned on. The heat pump will automatically add a set temperature difference (set in parameters 13.11, 13.13, 13.14) to adjust the setpoint of heating/cooling/DHW modes. Example: original heating setpoint 42 + heating set temp delta-T 5 (parameter 13.11) = new heating setpoint in SG-ready mode 47°C.

Mode 4 – Ordered operation: Power grid signal input “11”(SGA closed, SGB:closed), The heat pump is ordered to run

Heat pump will automatically adjust the temp. setpoint of heating/cooling/DHW modes to the maximum set temperature allowed by the system, and the electric heater can be selected to start(setting 13.12) in order to consume more power from Grid. Typically, this signal is sent when there is an overproduction of electric power in the grid and it allows to store thermal energy, to be exploited when there is a demand peak.

8. Failure code list

Failure Code

Failure code	Failure list	Possible reasons and solutions
E01	Communication failure between indoor PCB and outdoor PCB	Check the cable connection between indoor PCB and outdoor PCB. If cable is well connected, replace indoor PCB or outdoor PCB.
E02	Communication failure between outdoor PCB and Compressor drive PCB	Check the communication cable between outdoor power PCB and driver PCB. Check whether outdoor power PCB or driver PCB is broken.
E03	Compressor phase current failure	Check whether the power cable to compressor is broken or short-circuit.
E04	Compressor phase current overload (over-current)	Check whether the power cable to compressor is broken or short-circuit.
E05	Compressor drive failure	Check whether compressor drive PCB is broken, or cable to compressor is wrong connected.
E06	Compressor drive high/low DC voltage failure	Input voltage too high or too low.
E07	Input current failure	Check the current to outdoor unit, and compare it with the unit current shown on the operation panel. If the difference is not big, check whether the system has enough refrigerant (more likely it is not enough refrigerant that caused this abnormal low current). If the difference is big, outdoor power PCB is broken. Please replace it with a new one
E08	Outdoor PCB EEPROM Failure	Cut the unit power and short-circuit JP404 port on outdoor power PCB, repower the unit, cut power again and cancel the short-circuit on JP404 port. If still not OK, replace the outdoor power PCB.
E10	Communication failure between outdoor main PCB and driver PCB for fan motor	Check the communication cable between main PCB and driver PCB for fan motor. Check whether outdoor power PCB or driver PCB is broken.
E11	Compressor phase failure	Check the power cable of compressor is connected or not, check whether phase is wrong, or driver PCB is broken.
E12	Failure for abnormal temp. of Compressor Drive PCB	Check whether compressor driver has too high temperature, and the fan stops. Check whether the compressor driver PCB is broken, Replace it if necessary.
F01	Ambient temp. sensor failure	Check whether ambient temperature sensor is open, short-circuit or value drifts too much. Replace it if necessary.
F02	Outdoor evaporator coil temp. sensor failure	Check whether outdoor evaporator coil temperature sensor is open, short-circuit or value drifts too much. Replace it if necessary.
F03	Compressor discharge temp. sensor failure	Check whether compressor discharge temperature sensor is open, short-circuit or value drifts too much. Replace it if necessary.
F04	Compressor suction temp. sensor failure	Check whether Compressor suction temperature sensor is open, short-circuit or value drifts too much. Replace it if necessary.
F05	Evaporating pressure sensor failure	Check whether evaporating pressure sensor is open, short-circuit or broken. Replace it if necessary.
F06	Condensing pressure sensor failure	Check whether condensing pressure sensor is open, short-circuit or broken. Replace it if necessary.
F07	High pressure switch failure	If pressure switch is in open position when unit is in standby status, or 2 minutes after compressor stops, unit gives this failure. Check whether high pressure switch is broken or not well connected.
F08	Low pressure switch failure	If pressure switch is in open position when unit is in standby status, or 2 minutes after compressor stops, unit gives this failure. Check whether low pressure switch is broken or not well connected.

8. Failure code list

Failure code	Failure list	Possible reasons and solutions
F09	DC fan motor failure (FAN 1)	Speed of DC fan motor (FAN 1) can't reach the required value or no feedback signal. Please check whether the PCB or fan motor is broken.
F10	DC fan motor failure (FAN 2)	Speed of DC fan motor (FAN 2 for dual fan system) can't reach the required value or no feedback signal. Please check whether the PCB or fan motor is broken.
F11	Evaporating pressure too low for 3 times protection	If system too low pressure protection detected by evaporating pressure sensor happened 3 times in a certain period of time, it gives this failure code and unit can't be restarted until repowered. Check whether system has not enough refrigerant or leakage inside (more likely it is not enough refrigerant that caused this abnormal evaporating pressure); whether fan motor and water pump is working OK; whether condenser is blocked; whether EEV whether EEV works normally; whether water temperature too low, and whether water inlet & outlet temperature has too big difference in cooling
F12	Condensing pressure too high for 3 times protection	If system too high pressure protection detected by condensing pressure sensor happened 3 times in a certain period of time, it gives this failure code and unit can't be restarted until repowered. Check whether water flow rate is not enough (more likely it is not enough water flow rate that caused system build up too high pressure); whether fan motor and water pump is working OK; whether condenser is blocked; whether EEV works normally; whether water temperature too high, and whether water inlet&outlet temperature has too big difference
F13	Room temp.sensor failure - TR	Check whether room temperature sensor is open, short-circuit or value drifts too much. Replace it if necessary.
F14	DHW temp.sensor failure - TW	Check whether sanitary hot water temperature sensor is open, short-circuit or value drifts too much. Replace it if necessary.
F15	Heating/cooling temp. sensor failure	Check whether cooling/heating water temperature sensor is open, short-circuit or value drifts too much. Replace it if necessary.
F16	Water outlet temperature sensor failure - Tuo	Check whether water outlet temperature sensor is open, short-circuit or value drifts too much. Replace it if necessary.
F17	Water inlet temperature sensor failure - Tui	Check whether water inlet temperature sensor is open, short-circuit or value drifts too much. Replace it if necessary.
F18	Indoor coil temperature sensor failure - Tup	Check whether indoor coil temperature sensor is open, short-circuit or value drifts too much. Replace it if necessary.
F21	Mixing circuit 1 temp. sensor failure - Tv1	Check whether TV1 temperature sensor is open, short-circuit or value drifts too much. Replace it if necessary.
F22	Mixing circuit 2 temp. sensor failure - TV2	Check whether TV2 temperature sensor is open, short-circuit or value drifts too much. Replace it if necessary.
F27	Indoor PCB EEPROM Failure	Cut the unit power, connect CN213-5 and CN213-6 together, repower the unit and then cut the power and cancel the connect. If still not OK, replace the indoor PCB.
F28	DC pump PWN signal feedback failure	Check water pump cable connection; check power supply to water pump; check whether water pump is broken.
F29	Mixing valve 1 failure	Check MV1 cable connection; check whether PCB output voltage signal; check whether MV1 is broken.
F30	Mixing valve 2 failure	Check MV2 cable connection; check whether PCB output voltage signal; check whether MV2 is broken.
F31	Economizer inlet temp. sensor failure	Check whether the sensor is open, short-circuit or value drifts too much. Replace it if necessary.
F32	Economizer outlet temp. sensor failure	Check whether the sensor is open, short-circuit or value drifts too much. Replace it if necessary.
F33	Defrosting temp. sensor failure	Check whether the sensor is open, short-circuit or value drifts too much. Replace it if necessary.
F34	Water tank temp. sensor failure	Check whether the sensor is open, short-circuit or value drifts too much. Replace it if necessary.
F35	Compressor discharge temp. too high for 3 times protection	If it gives this failure code,unit can't be restarted until repowered.Check whether system is lacking of enough refrigerant, or blocked, whether the system has air inside, or water flow rate too small

8. Failure code list

Failure code	Failure list	Possible reasons and solutions
P01	Main line current protection	Input current too high or too low, or system works in over-load condition. Unit recovers automatically after 5 minutes when it happened the first time. If same failure happened 3 times in a certain period of time, unit stops until repowered. Check unit input current. Check whether fan motor and water pump is working OK; whether condensor is blocked; whether water temperature too high, and whether water inlet&outlet temperature has too big difference
P02	Compressor phase current protection	Compressor input current too high or too low, or system works in over-load condition. Check compressor input current. Check whether fan motor and water pump is working OK; whether condensor is blocked;whether water temperature too high, and whether water inlet&outlet temperature has too big difference
P03	Compressor drive protection	Compressor drive failure. Check whether cable is broken or loosen. Check whether compressor driver PCB or compressor is broken.
P04	Compressor oil return protection	If unit has been continuously working in low speed for certain period of time, unit starts this protection to suck compressor oil back into compressor. This is a normal protection and doesn't need any treatment.
P05	High pressure switch protection	If system pressure is too high or too low, it activates this protection. Unit recovers automatically after 5 minutes when it happened the first time. If same failure happened 3 times in a certain period of time, unit stops until repowered. Check whether fan motor and water pump is working OK; whether condensor is blocked; whether water temperature too high, and whether water inlet&outlet temperature has too big difference
P06	High pressure too-high protection	This protection happens when system pressure is higher than the set compressor speed-down pressure point. If after slow down the compressor speed but pressure still higher than the protection point, compressor stops. Check whether water temperature set value is too high; whether system water flow rate too small; whether EEV works normally; whether air circulates fluently in cooling mode; whether water inlet&outlet temperature has too big difference
P07	Compressor preheating	This is a normal protection and doesn't need any treatment.
P08	Discharge temp. too high protection	Check whether water temperature set value is too high, especially when ambient temperature is low; whether water flow rate too small; whether system is lacking of enough refrigerant.
P09	Outdoor coil temp. sensor too high in cooling	Check whether air circulates fluently in outdoor unit.
P10	AC high/low voltage protection	Unit input voltage too high or too low. Check the voltage of unit power supply.
P11	Outdoor ambient temp. out of working range	Ambient temperature is too high or too low for unit to work.
P12	Compressor speed limit by ambient temp.	This is a normal protection and doesn't need any treatment.
P13	Low pressure switch protection	If system pressure reach the set value of pressure switch, it activates this protection. Unit recovers automatically after 1 minutes when it happened the first time. If same failure happened 3 times in one hour, unit stops until repowered. Check whether there is leakage on refrigerant system, or EEV has no action or is blocked.
P14	Anti-freezing protection-stage 1 active	Ambient temp. is too low,and inlet or outlet water temp. is too low.
P15	Anti-freezing protection-stage 2 active	Ambient temp. is too low, and inlet or outlet water temp. is too low.
P17	Condenser deltaT too high	Check whether there is air or dirty inside water system, or water flow rate is too small
P18	Evaporating pressure too low protection	If system pressure reach the set value of pressure sensor, it activates this protectio. Unit recovers automatically after 30 seconds when it happened the first time. If same failure happened 3 times in one hour, unit stops until repowered. Check whether there is leakage on refrigerant system, or EEV has no action or is blocked.
P19	Too high input voltage protection	If the voltage is detected higher than set value,it activates this protection. Unit recovers automatically in 60 seconds when it comes to normal. Check whether the input voltage is too high, or change driver PCB

8. Failure code list

Failure code	Failure list	Possible reasons and solutions
P20	Too low input voltage protection	If the voltage is detected lower than set value, it activates this protection. Unit recovers automatically in 60 seconds when it comes to normal. Check whether the input voltage is too high, or change driver PCB
P21	Too high input current protection	If the current is detected higher than set value, it activates this protection. Unit recovers automatically in 60 seconds when it comes to normal. Check whether the current is too high, or refrigerant is too much, or change driver PCB
P22	Too low input current protection	If the current is detected lower than set value, it activates this protection. Unit recovers automatically in 60 seconds when it comes to normal. Check whether the current is too low, or refrigerant is too little, or change driver PCB
P25	Indoor coil temp. sensor failure in heating	Check whether there is air or dirty inside water system, or water flow rate is too small, or refrigerant system is blocked.
P26	Service Lock	If the service time is up, find installer to unlock it.
P27	Power supply phase protection	Check whether there is wrong phase or there is no voltage on one phase.
S01	Anti-freezing protection in cooling	1.Check whether set temperature for cooling is too low; whether system has too small water flow rate; check water system especially the filter.2.Check whether system has not enough refrigerant inside by measuring the evaporating pressure.
S02	Too small water flow rate protection	System water flow rate is less than minimum allowable flow rate. Check the water system, especially the filter; check the working status of water pump.
S03	Water flow switch failure	Water flow switch failed to work. Check whether flow switch is broken or not well connected.
S04	Communication failure between operation panel and indoor PCB	Communication failure between operation panel and the indoor PCB. Check the cable connection in between. Communication data lost too much. Check whether communication cable is longer than 30M; whether there has a source of the disturbance nearby the unit. Unit recovers when communication recovers.
S05	Communication failure between operation panel and outdoor PCB	Communication failure between operation panel and the outdoor PCB. Check the cable connection in between. Check whether the last three switches on outdoor power PCB are set to 001; whether last three switches on indoor PCB are set to 001. Unit recovers when communication recovers.
S06	Water outlet temp. too low (Tuo)	Compressor stops if water outlet is lower than 5 °C in cooling mode. Check whether temperature sensor Tc is OK and well connected;whether set water temperature too low;whether system flow rate too small.
S07	Water outlet temp. too high (Tuo)	Compressor stops if water outlet is higher than 57 °C in heating or hot water mode. Check whether temperature sensor Tc and Tw is OK and well connected; whether set water temperature too high; whether system flow rate too small.
S08	Defrost failed for 3 times	System water temperature is too low for defrosting. Please either set the temperature higher, have the back-up heating source connected or close some heating circuit so to let the system has enough high water temperature for a safe defrosting.
S09	Defrost failed	If water outlet temperature is lower than 15 °C during defrosting, water may freezing up in the plate heat exchanger and cause damage, so unit will quit current defrosting mode. It will try again in next defrosting cycle but if it continuously failed to make the defrosting for 3 times, it shows S08 failure code and can only be restarted by repower the unit. Please either set the temperature higher, have the back-up heating source connected or close some heating circuit so to let the system has enough high water temperature for a safe defrosting.
S10	Not enough water flow for 3 times	If "too small water flow rate protection" happens over 3 times in certain period of time, it gives this failure code and unit stops until repower.his failure means the system water flow rate is less than minimum allowable flow rate. Check the water system, especially the filter;check the working status of water pump.
S11	Anti-freezing protection in cooling for 3 times	If "Anti-freezing protection in cooling" happens over 3 times in certain period of time, it gives this failure code and unit stops until repower.1.Check whether set temperature for cooling is too low; whether system has too small water flow rate; check water system especially the filter.2.Check whether system has not enough refrigerant inside by measuring the evaporating pressure.
S12	Floor curing failure	If floor curing function can't be finished in the maximum allowable time, it shows this information. Unit will go back to normal working mode,with failure information shown on the display. Failure information can only be erased until repower or start the floor curing function again.

8. Failure code list

Failure code	Failure list	Possible reasons and solutions
S13	4-way valve failure	Check whether the ambient temp. sensor and outdoor evaporator coil temp. sensor are well connected. Check whether the 4-way valve is switched well.
S14	3-way valve failure	Check whether the DHW temp. and water inlet temp. is correct. Check whether the water flow rate is not enough in hydraulic system. Check whether the hydraulic system is blocked. Check whether the 3-way valve is switched well.
S15	Overall water outlet temperature sensor failure	Check whether overall outlet temperature sensor is open, short-circuit or value drifts too much. Replace it if necessary.
S16	Overall water inlet temperature sensor failure	Check whether overall inlet temperature sensor is open, short-circuit or value drifts too much. Replace it if necessary.
S17	Outdoor PCB failure	One of outdoor PCB has failure. Pls check the failure code for this outdoor unit, and solve it.
S18	Communication failure of all outdoor PCB	Check whether the communication cable between indoor PCB and all outdoor units are connected well, or replace indoor PCB.
S19	Ambient temp. sensor failure	If ambient temp. of all outdoor units failed, it activates this failure. Check whether ambient temp. sensors of all outdoor units are open, short-circuit or value drifts too much. Replace it if necessary.
S20	All outdoor PCB failure	If all outdoor units stops for 3 times and be locked , it activates this failure. Check failure code for all outdoor units, and then solve it.

Note 1: For single compressor system, failure code is 3 digits as ***, like P01.

Note 2: For double compressor system, if the failure code is for either one of systems, the failure code has 4 digits, 1*** for system 1, 2*** for system 2. *** means code for each system. for example, 1P01 for system 1, 2P01 for system 2.

Note 3: For double compressor system, for common failure of the whole system, the code is 3 digits, like ***. For example, Water outlet temperature sensor failure is common failure for whole water system, the code will be F16.



ES Heat Pumps AB, 44138 Alingsås, Sweden
info@energysave.se
www.energysave.se

Thank you for choosing our quality product.
Please read this manual carefully before use and
follow the instructions to operate the unit in order
to prevent damages on the device or injuries to staff.

Specifications are subject to change with product
improvements without prior notice. Please refer to the
specification sticker on the unit for upgraded specifications.